



CATIA V5 & SolidWorks 2010 Design

By Ayman A. Salem
Bachelor Degree In Mechanical Engineering 2010

Specialization in Thermo Fluids & Propulsion
Concordia University, Montreal, Quebec

CATIA V5 R16 & R19

Wireframe & Surfaces Design

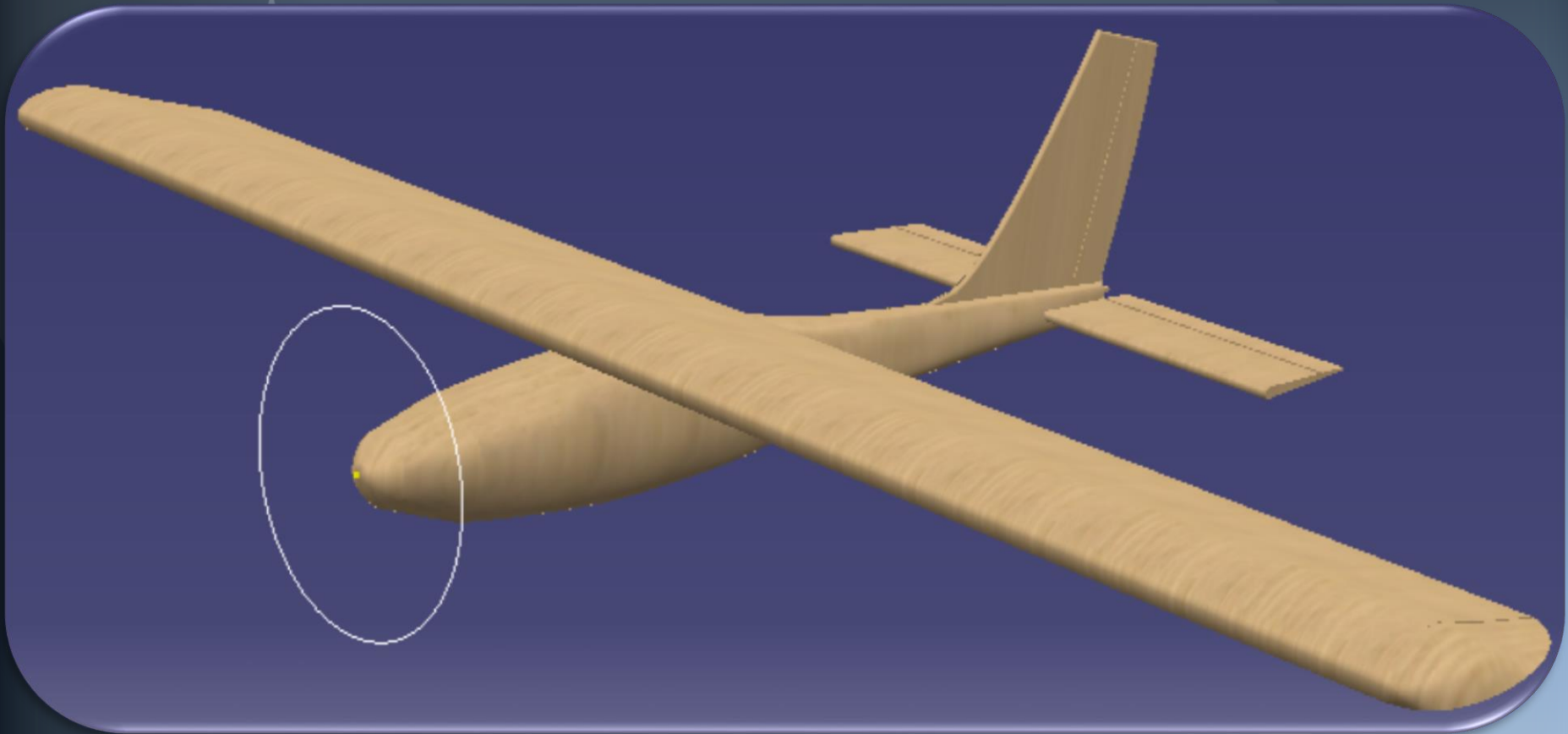

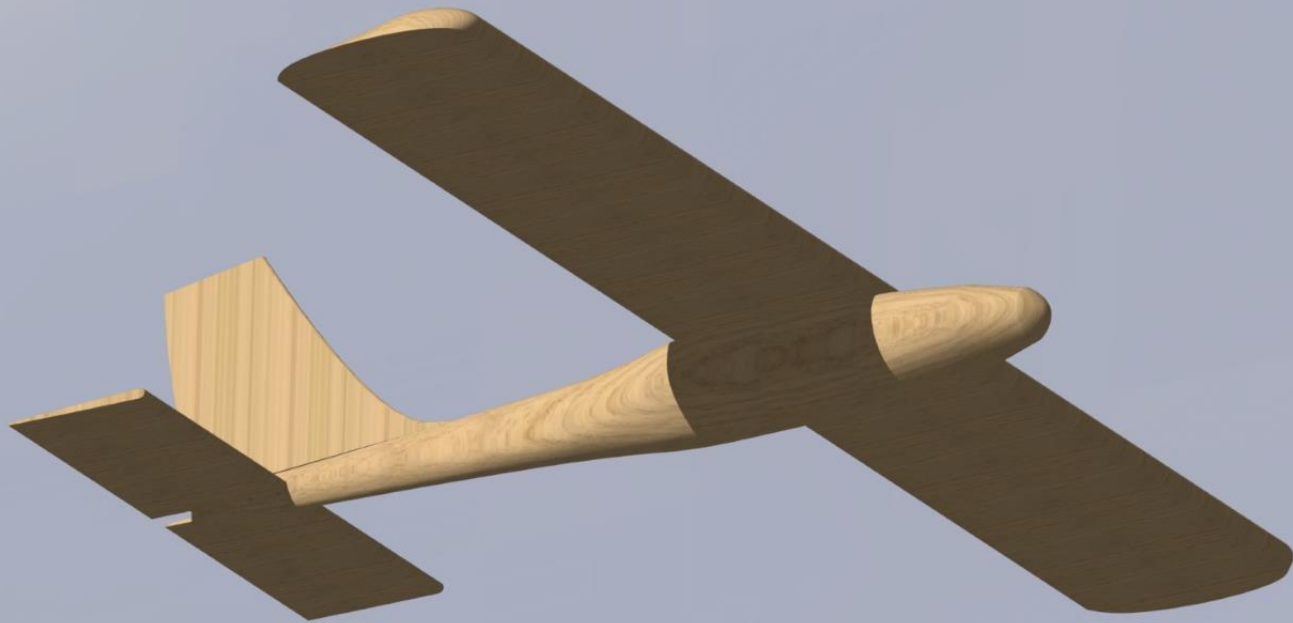

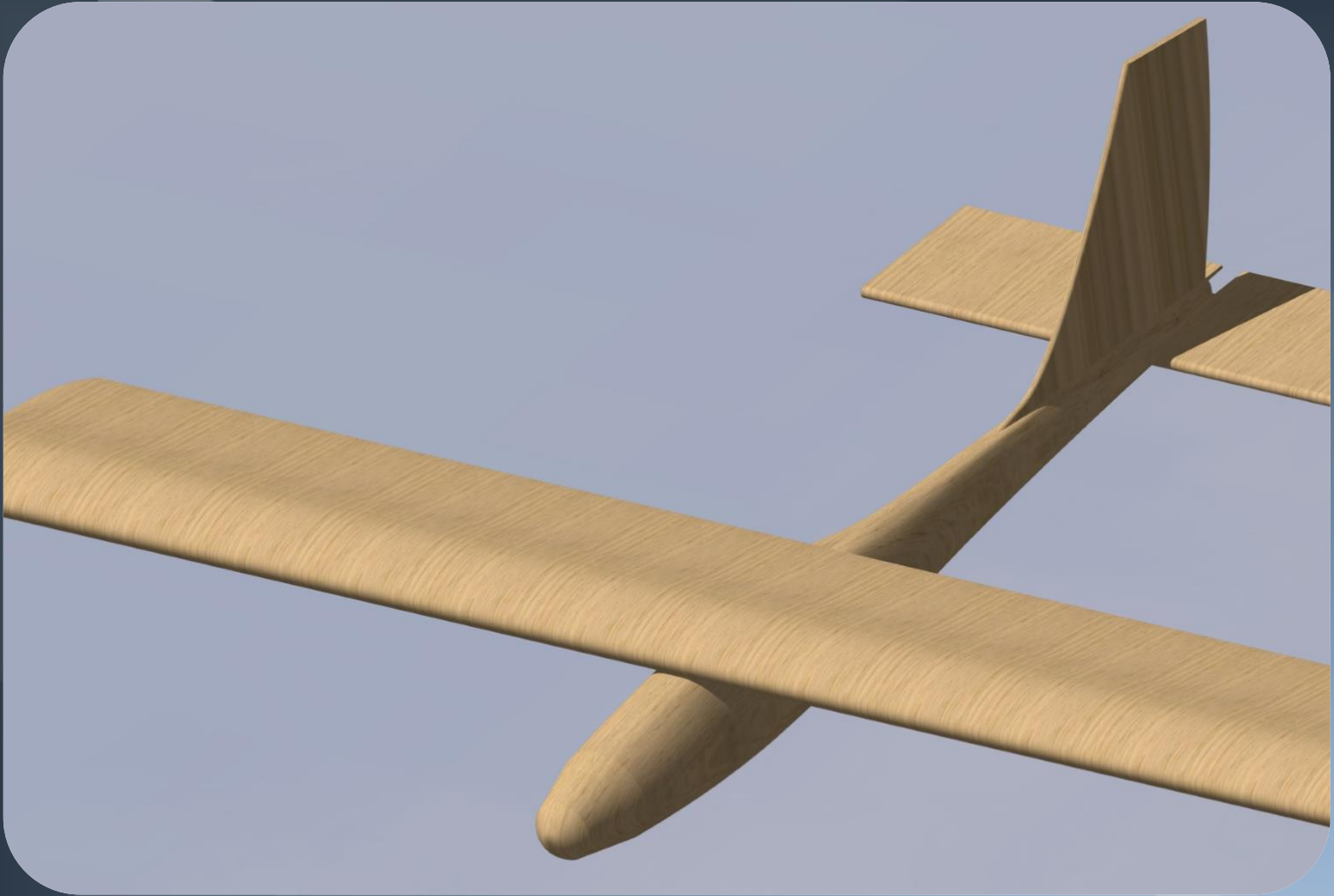

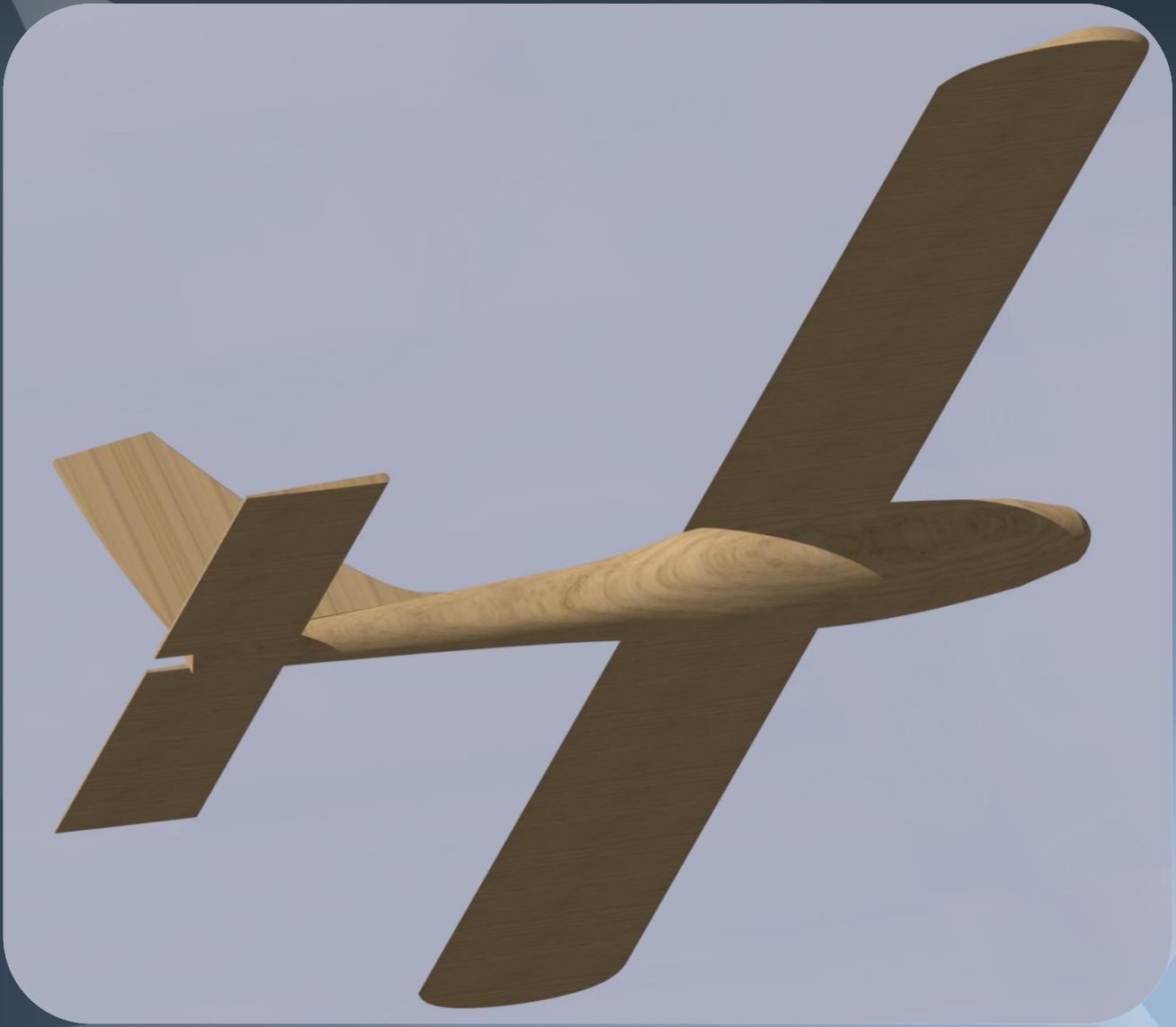

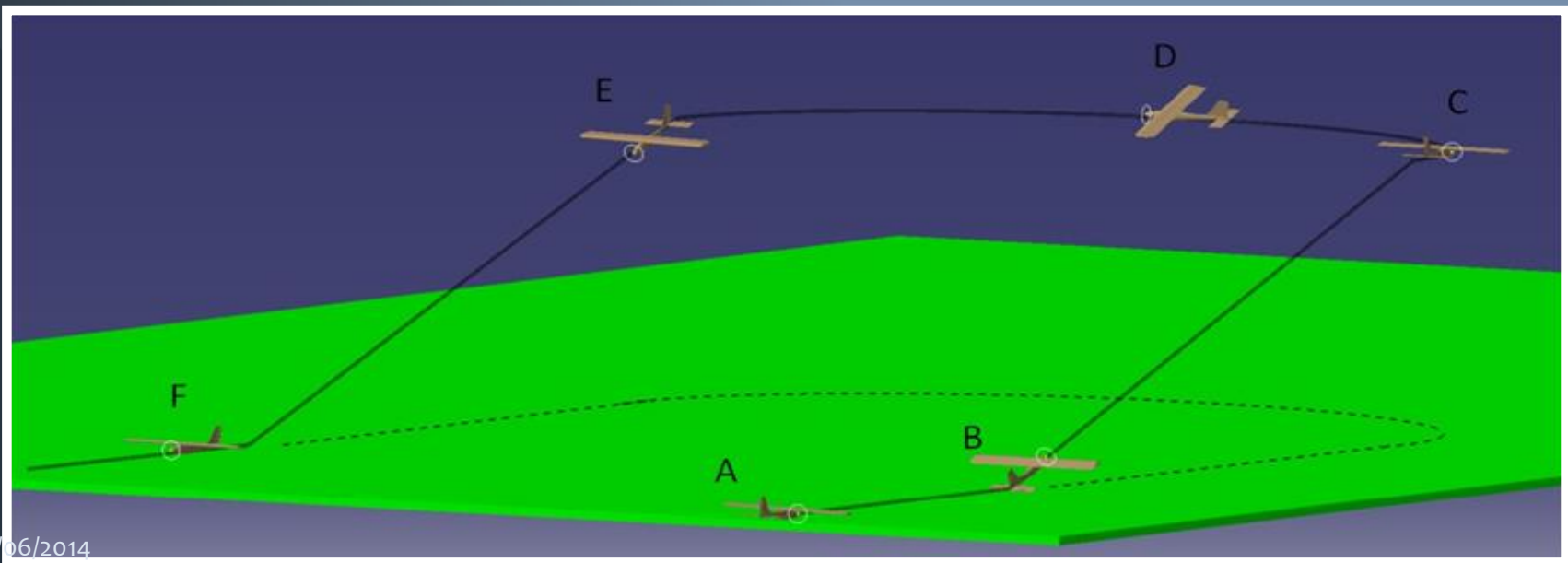
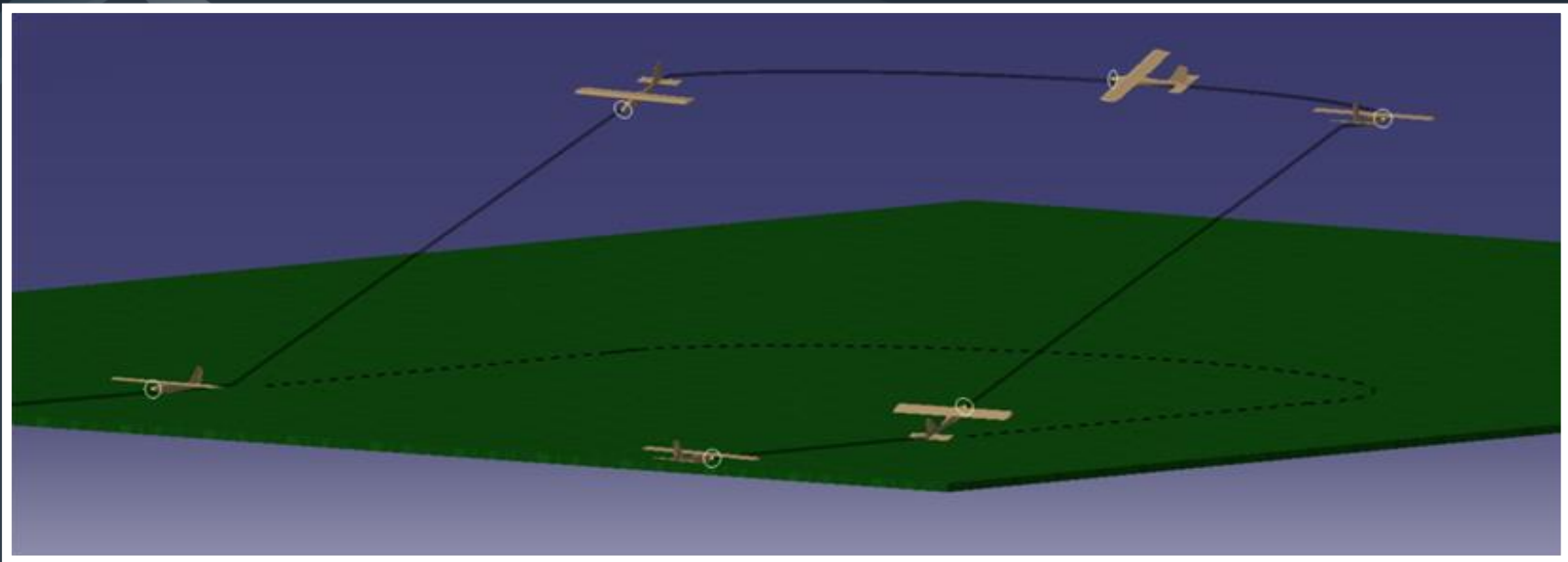

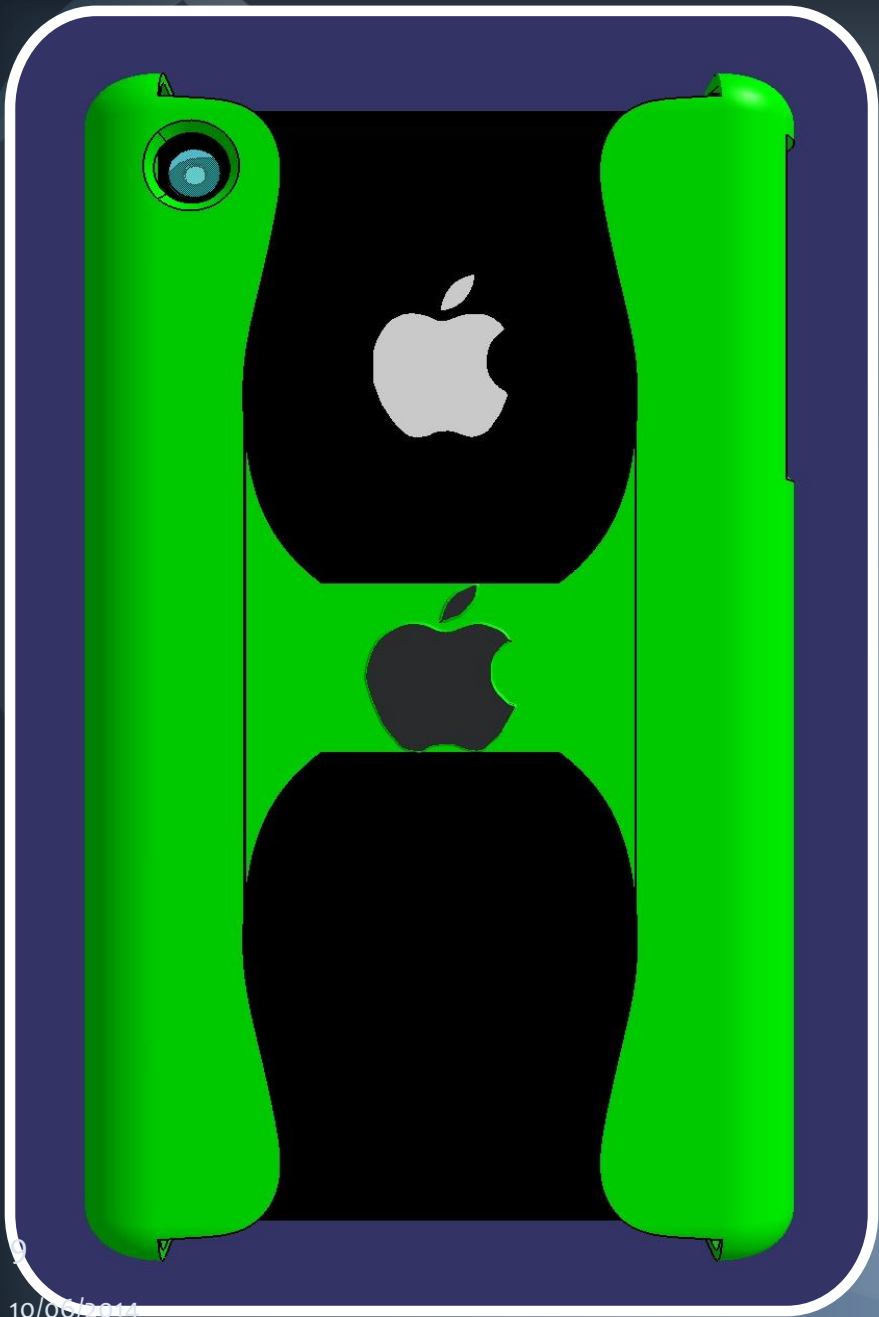

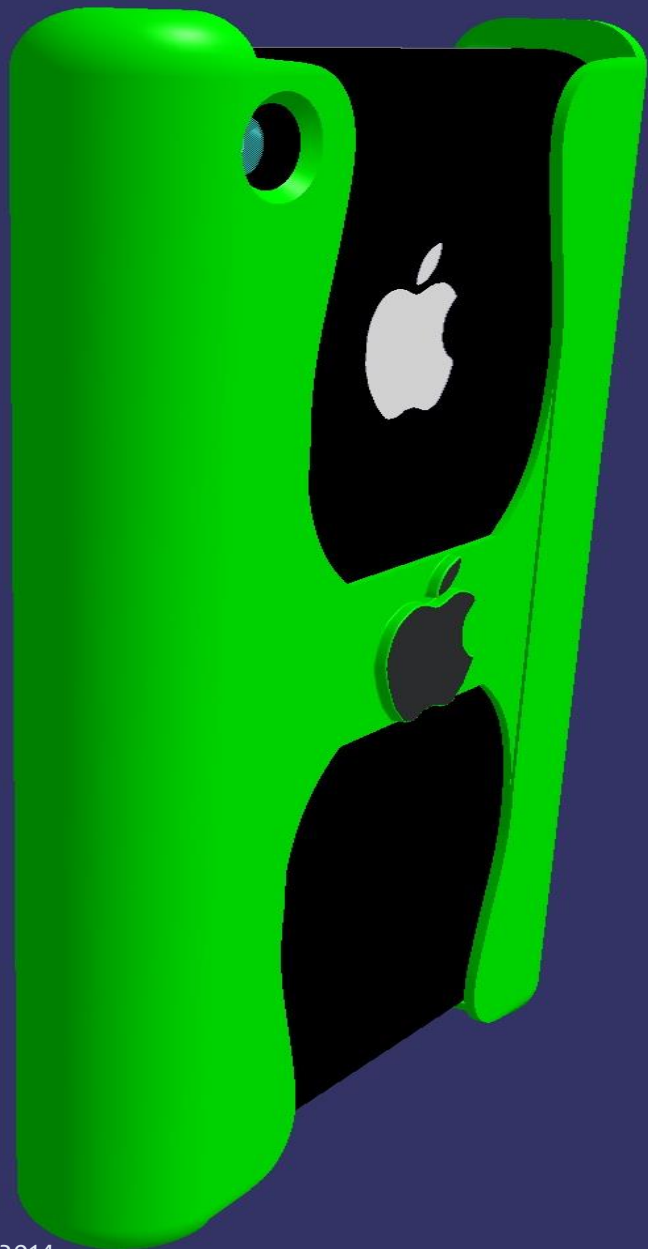

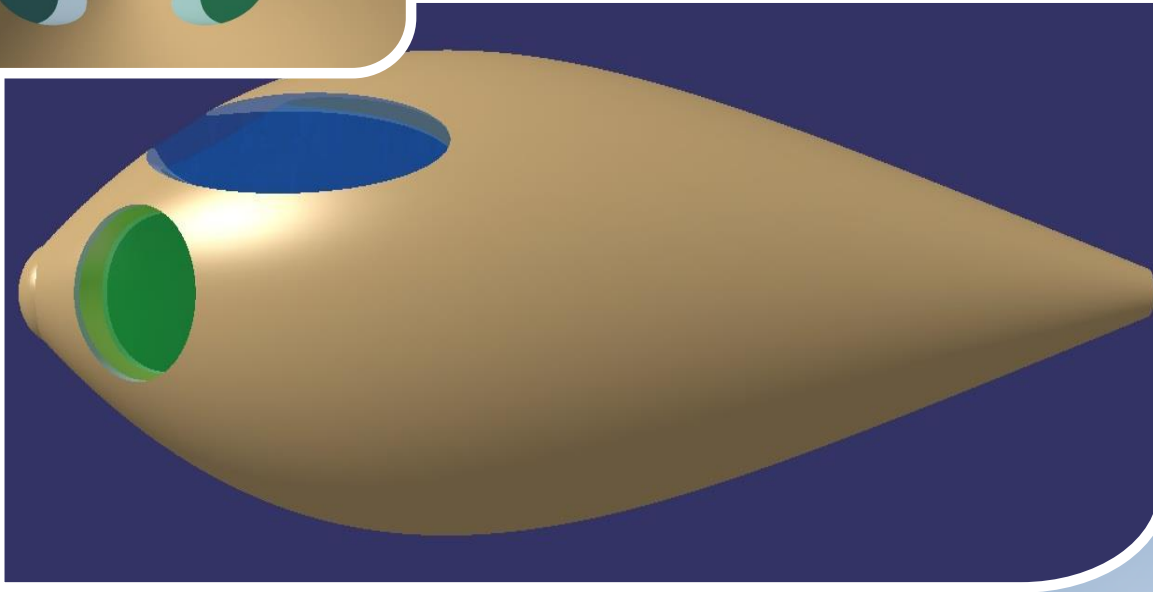
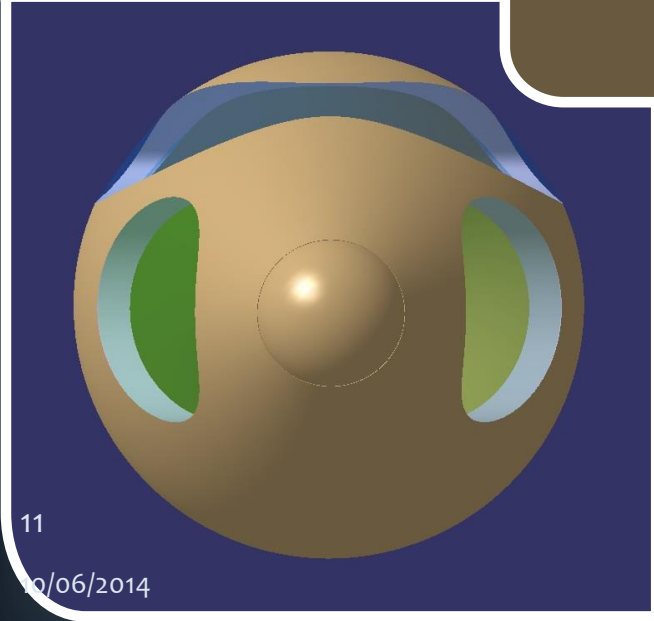
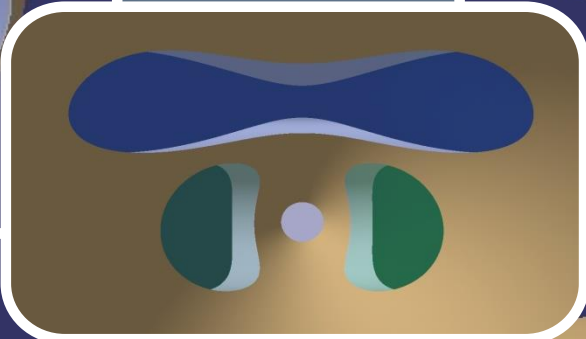
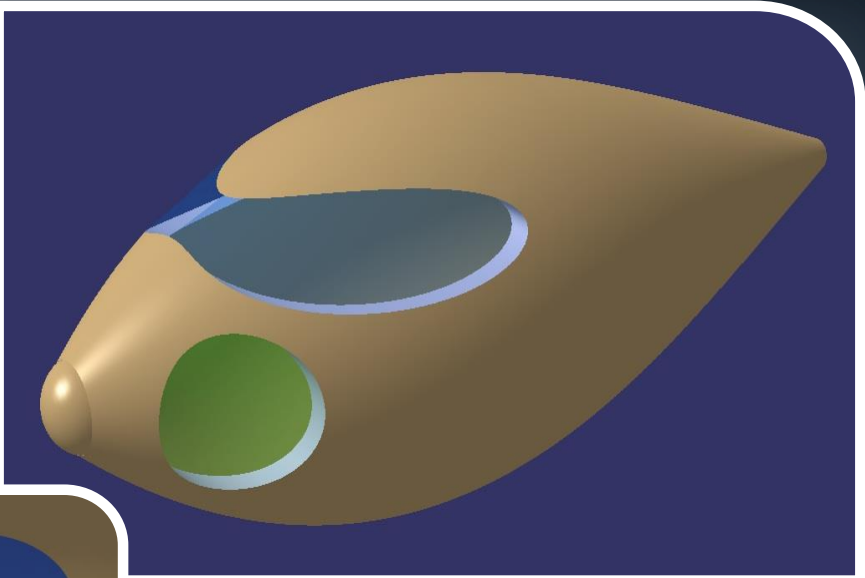

FreeStyle & Generative Shape Design

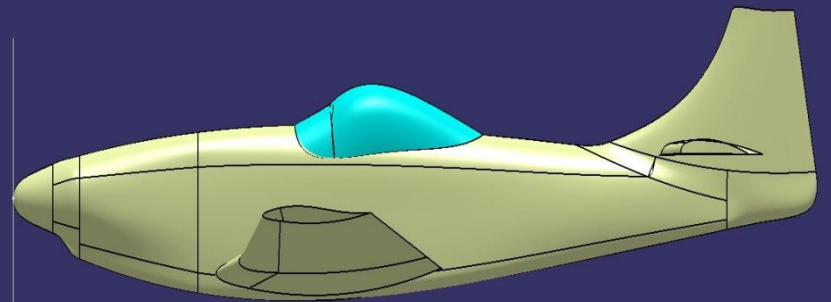
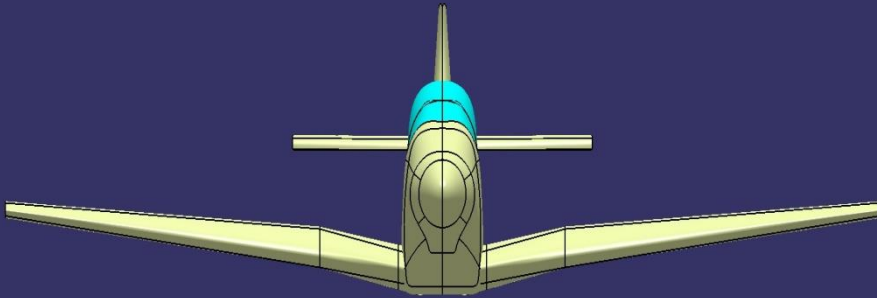
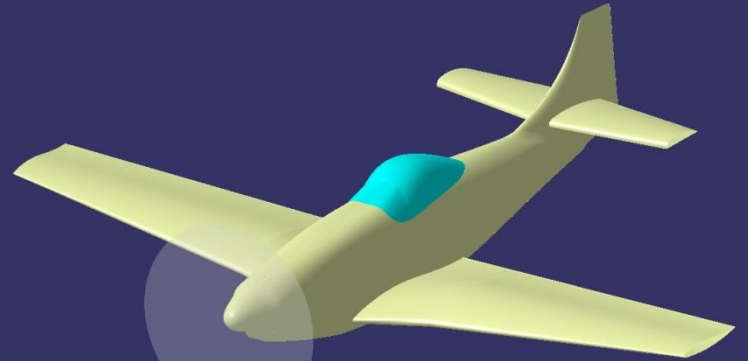
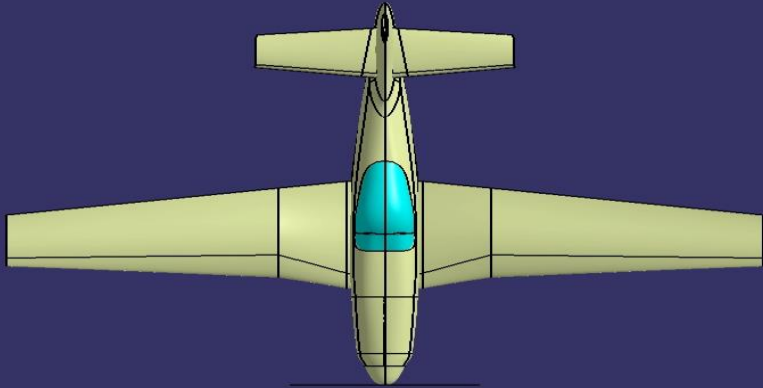

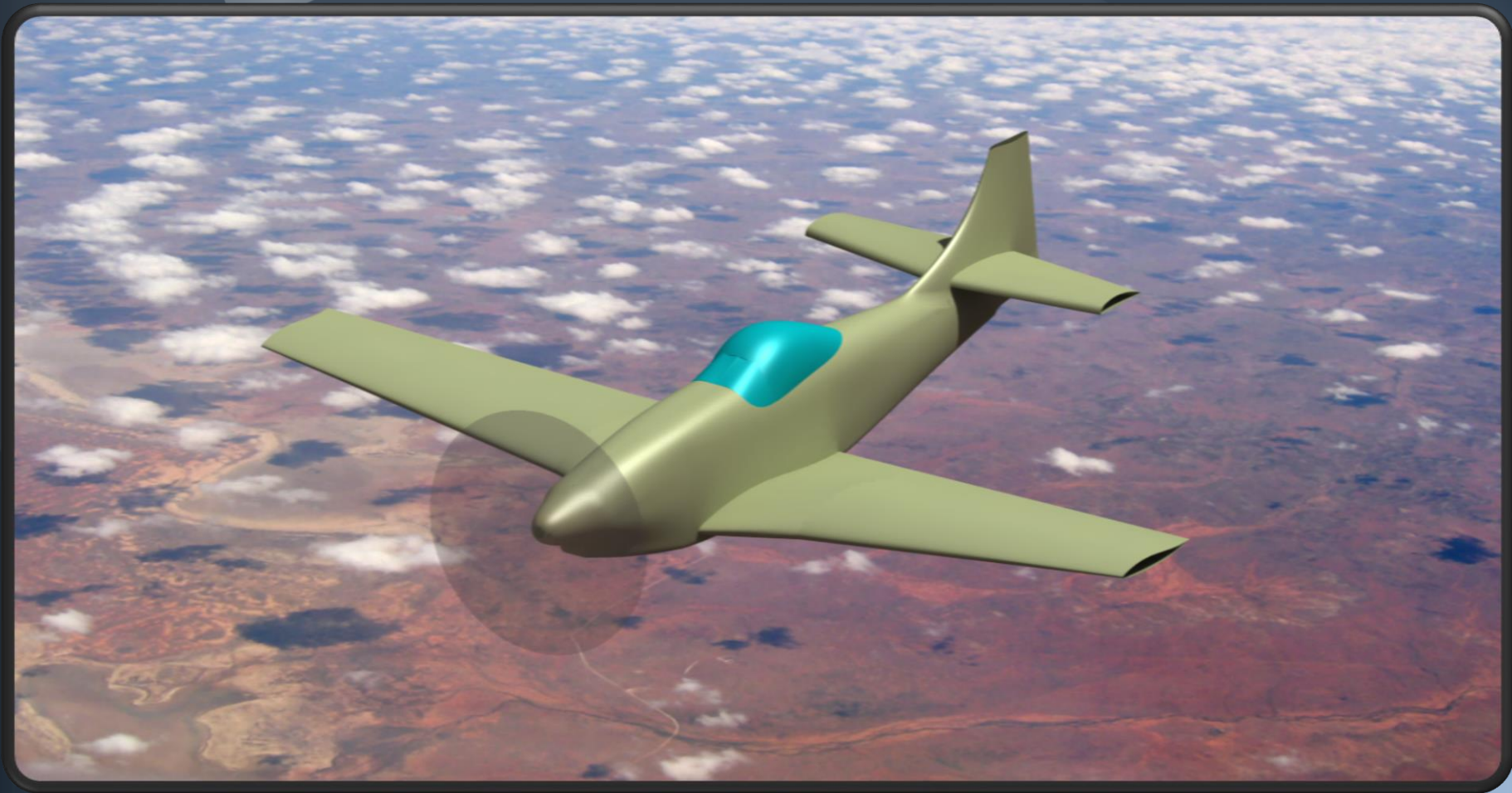

Assembly Design

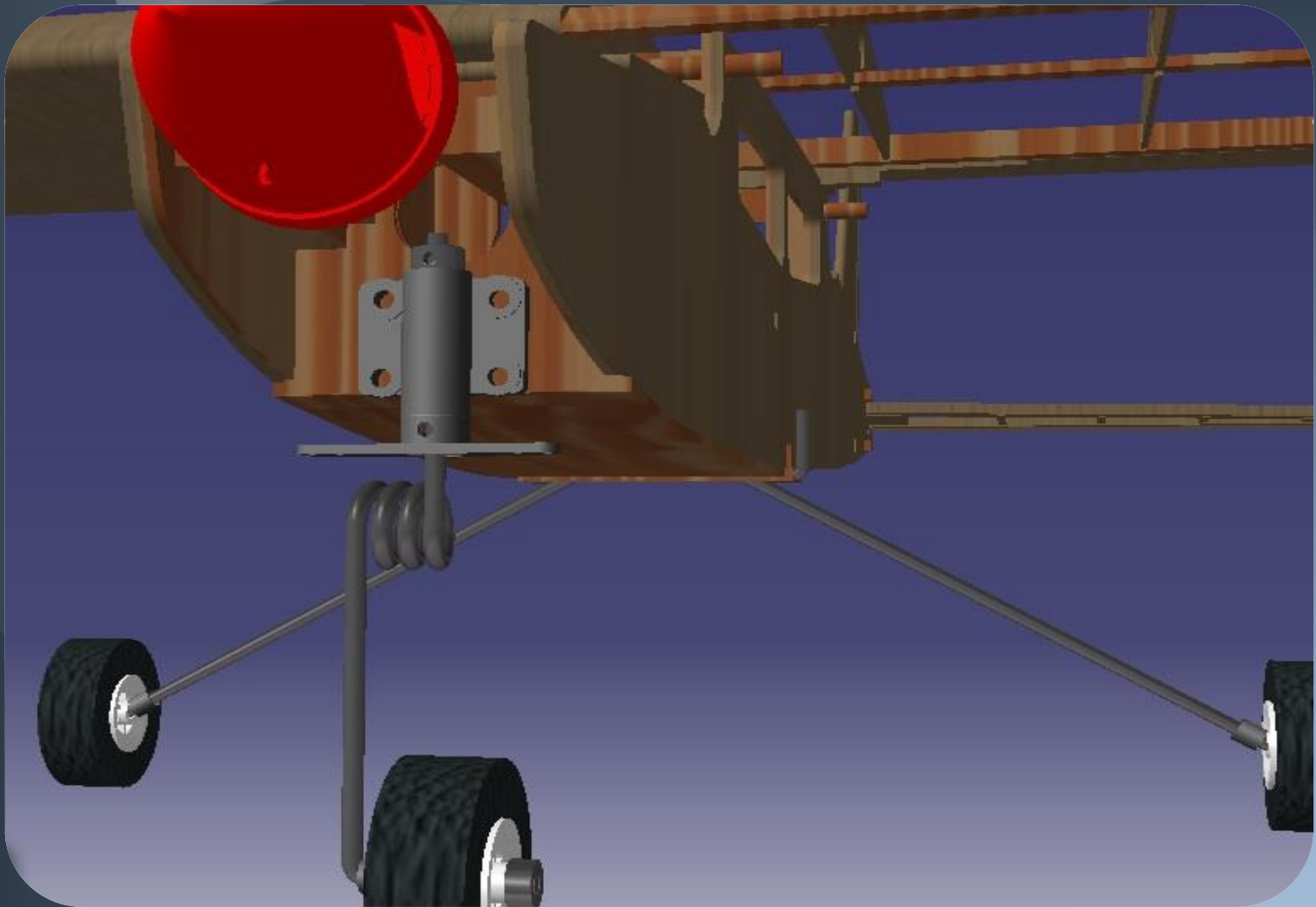

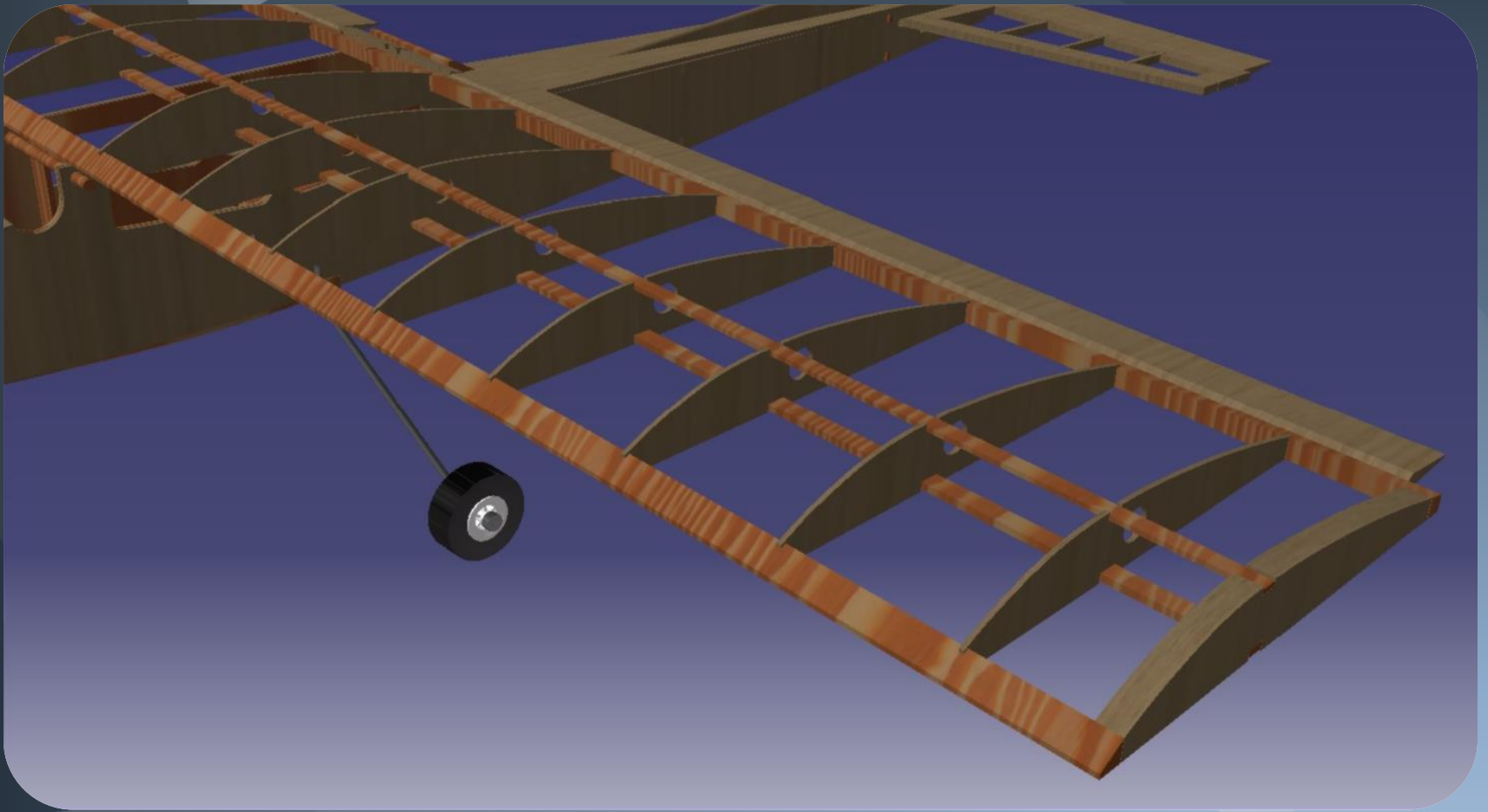

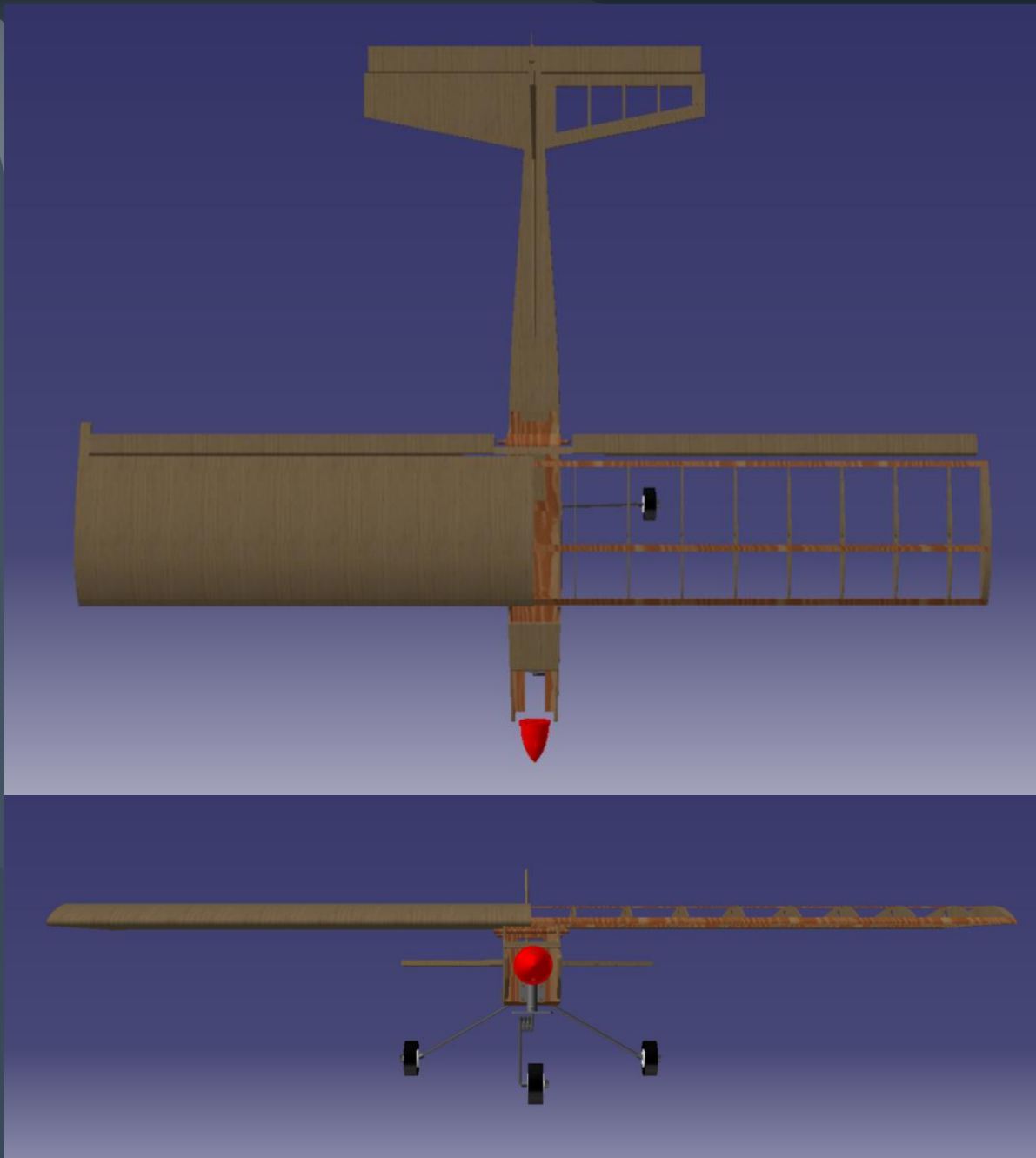

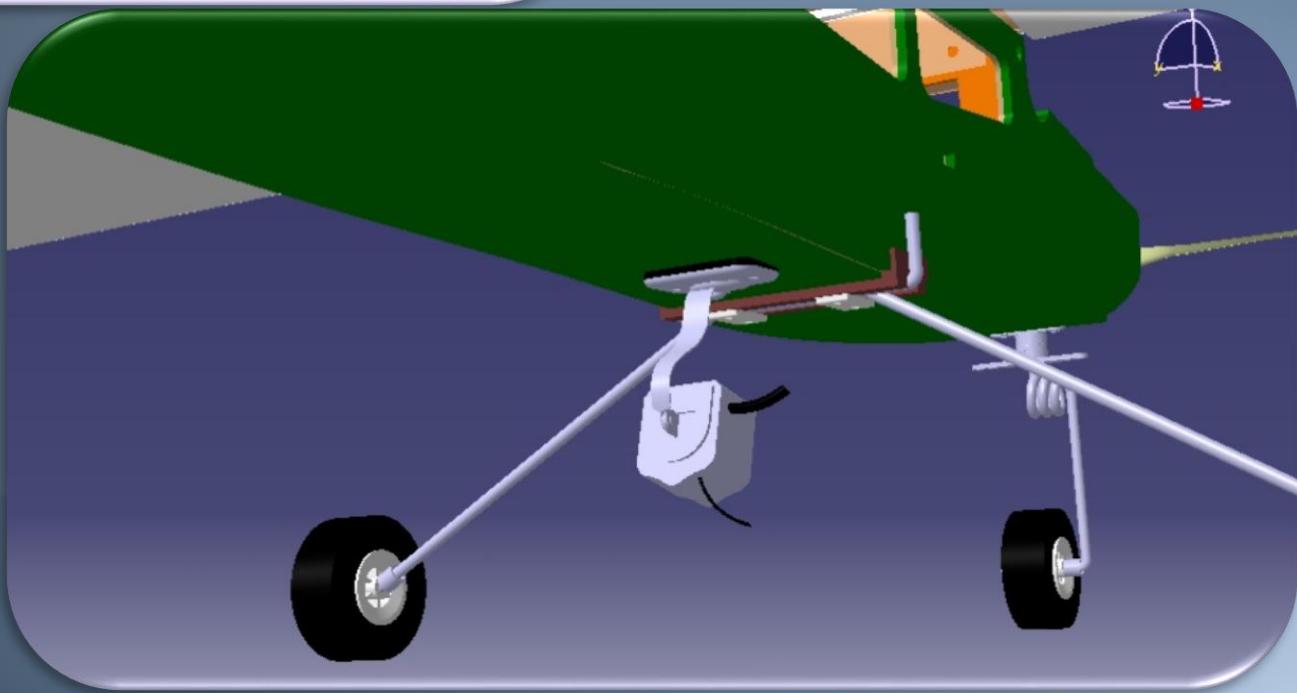
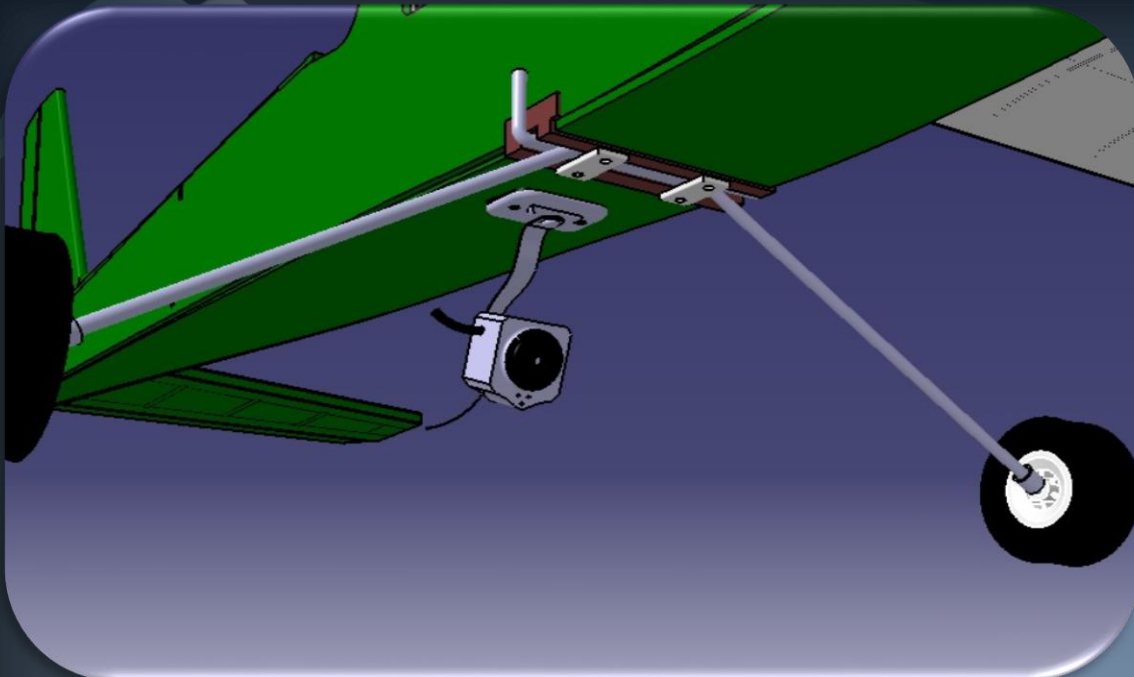

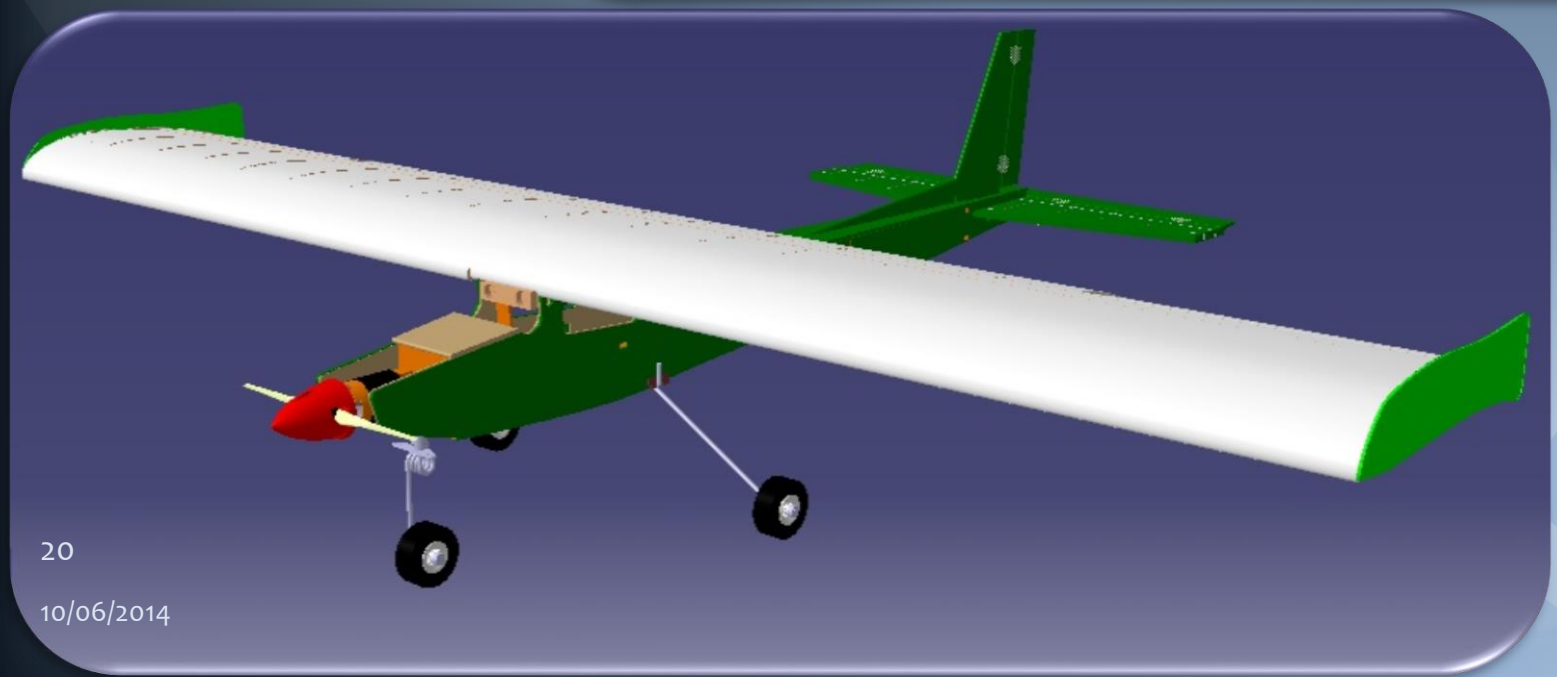
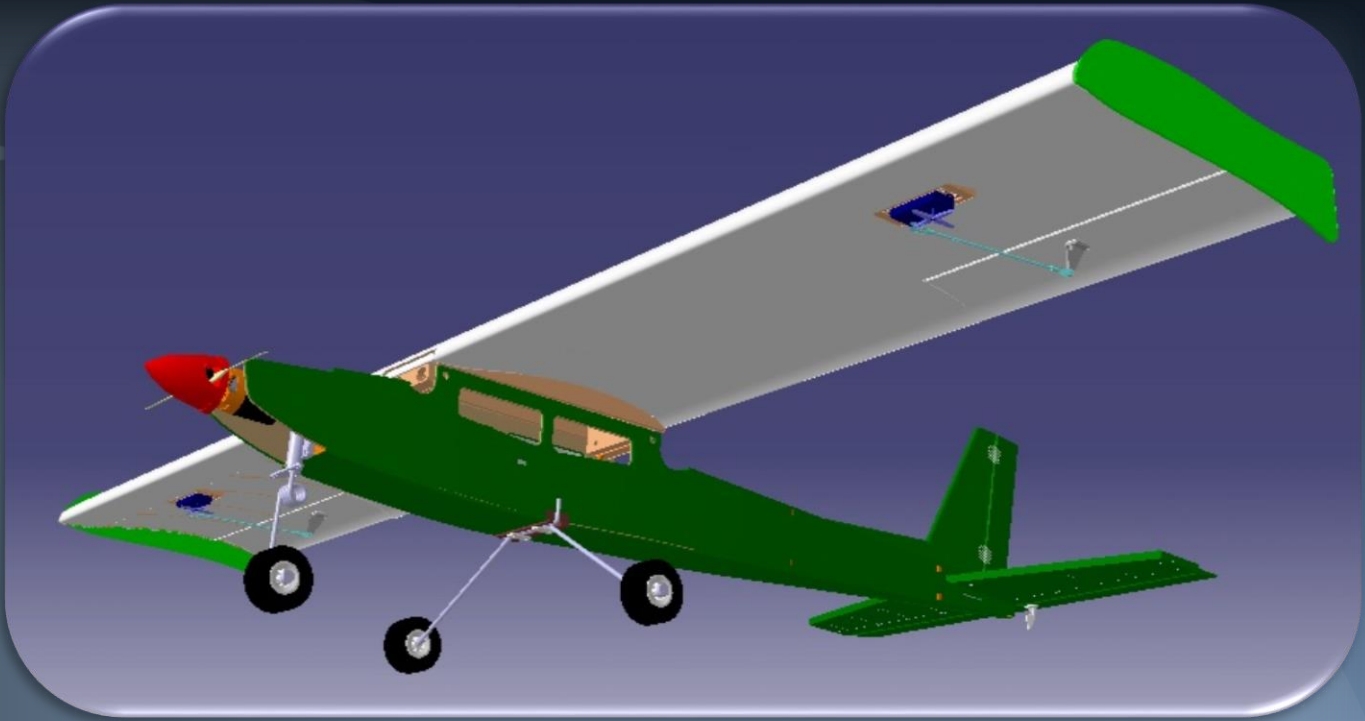

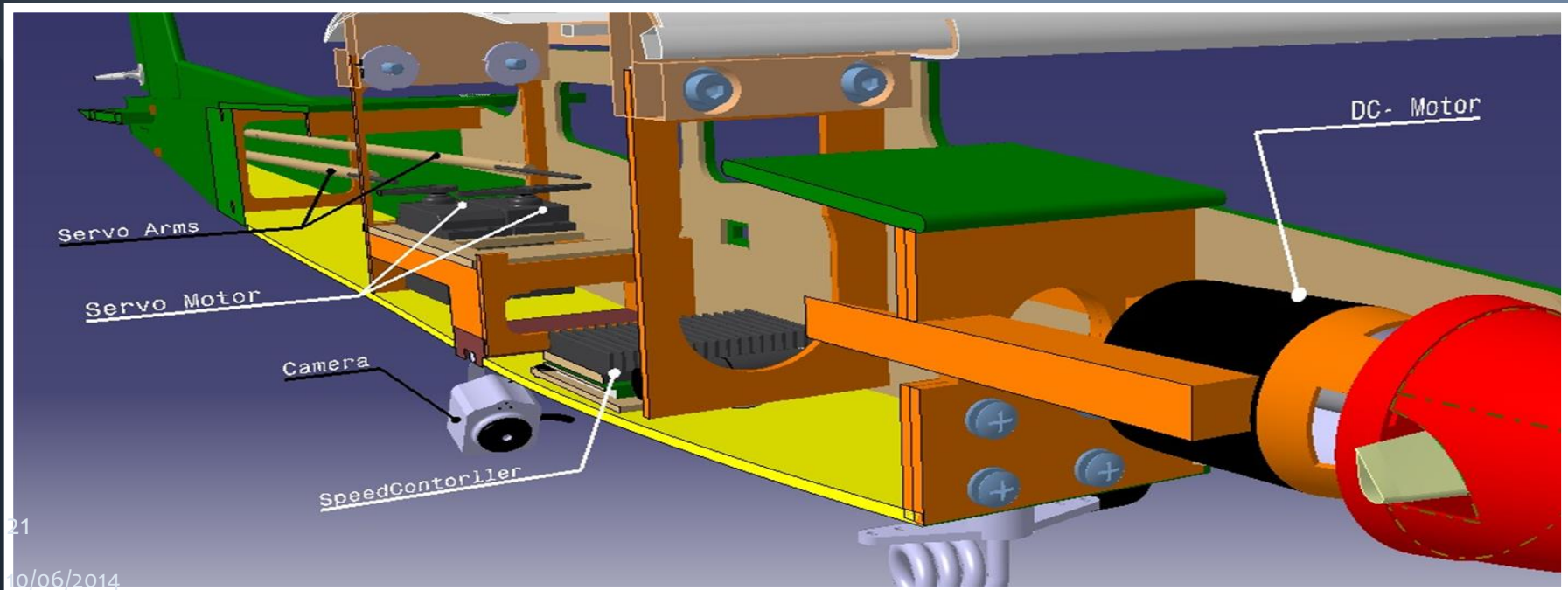
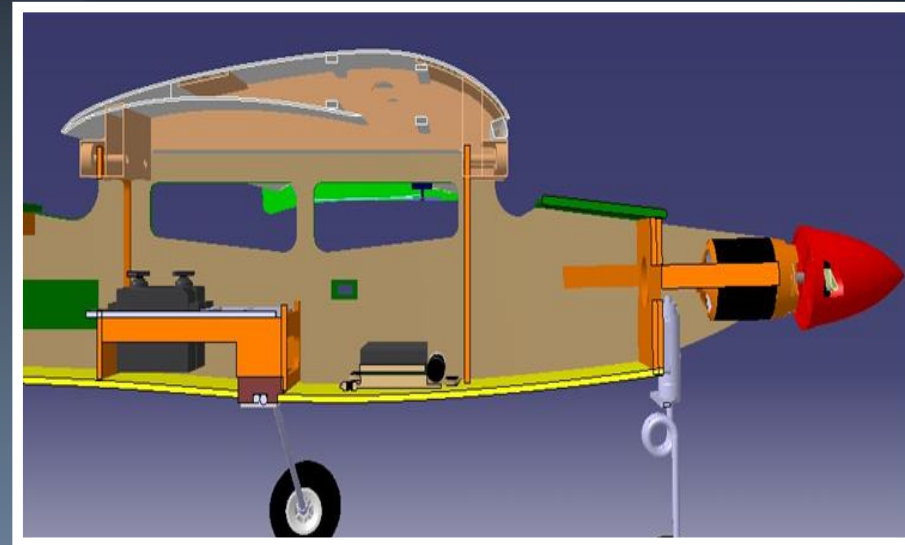
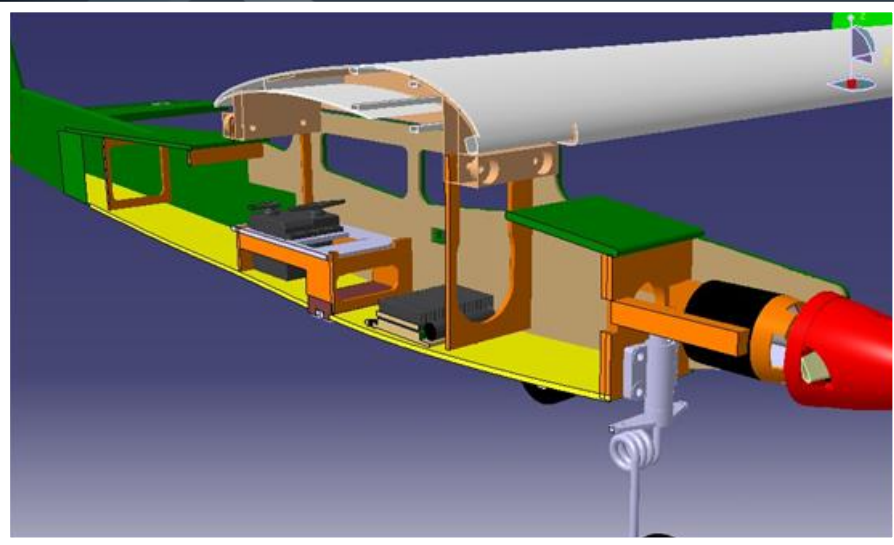

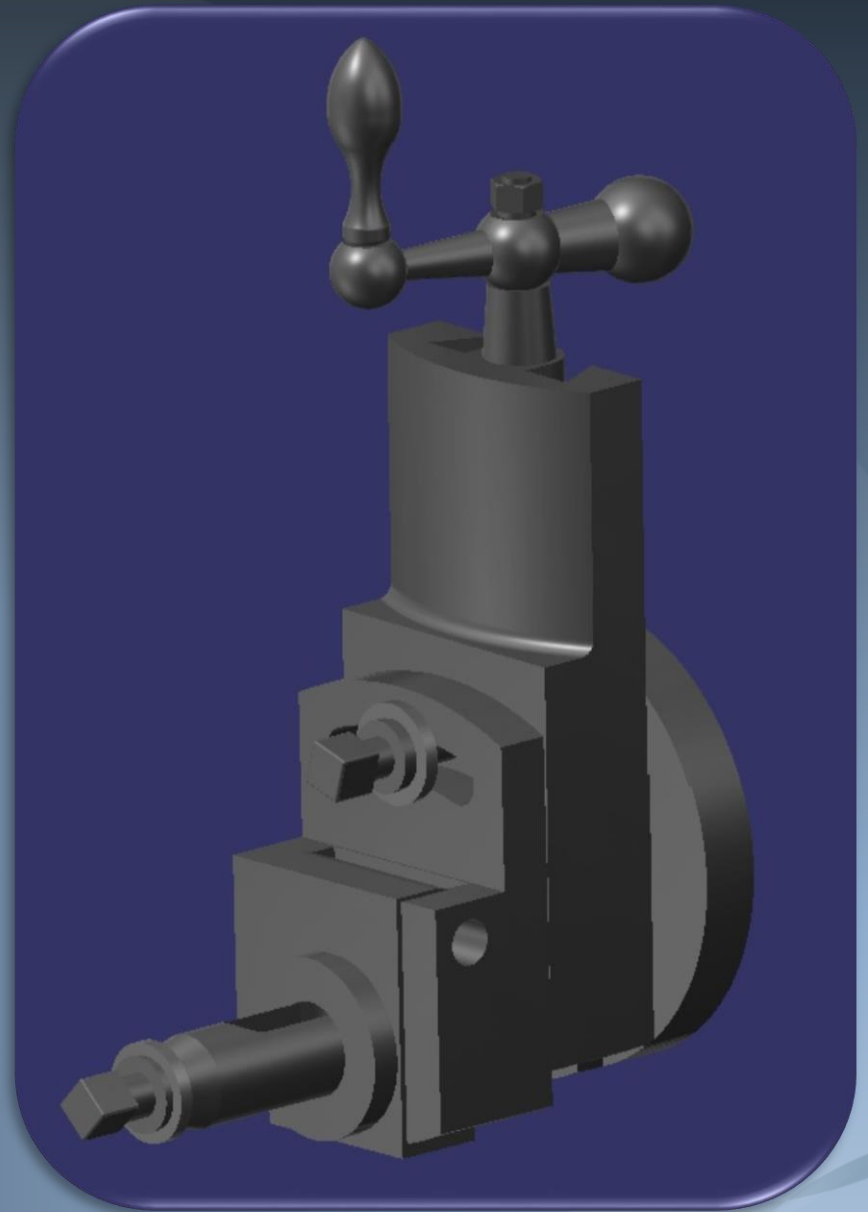

Wooden Gear Clock

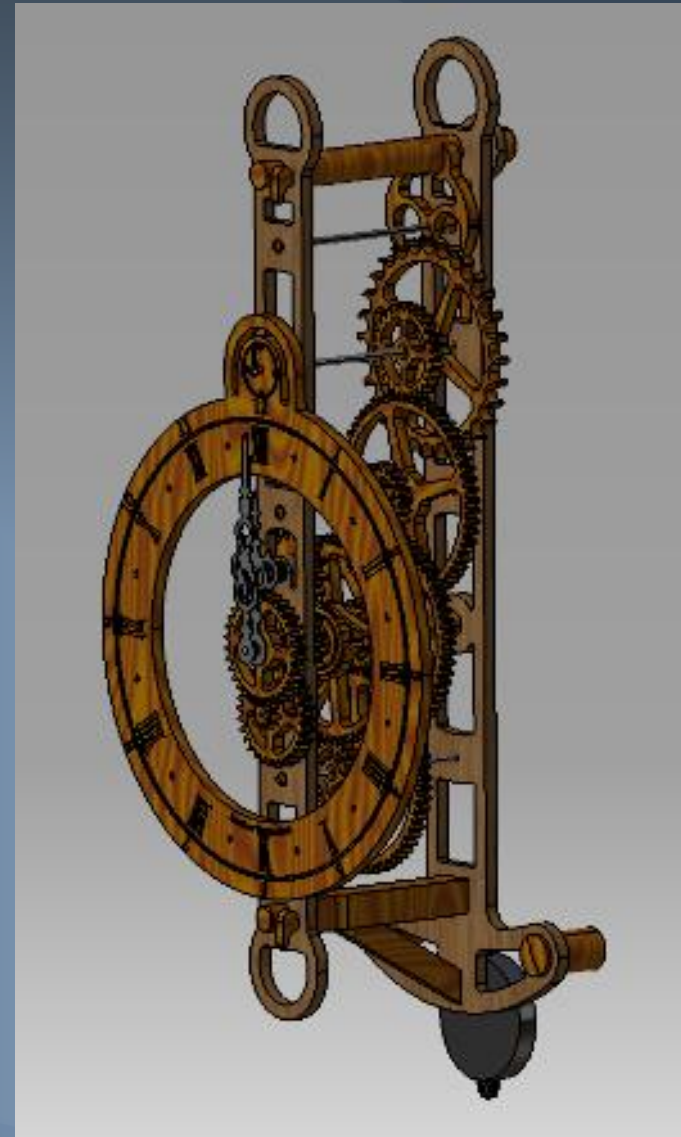

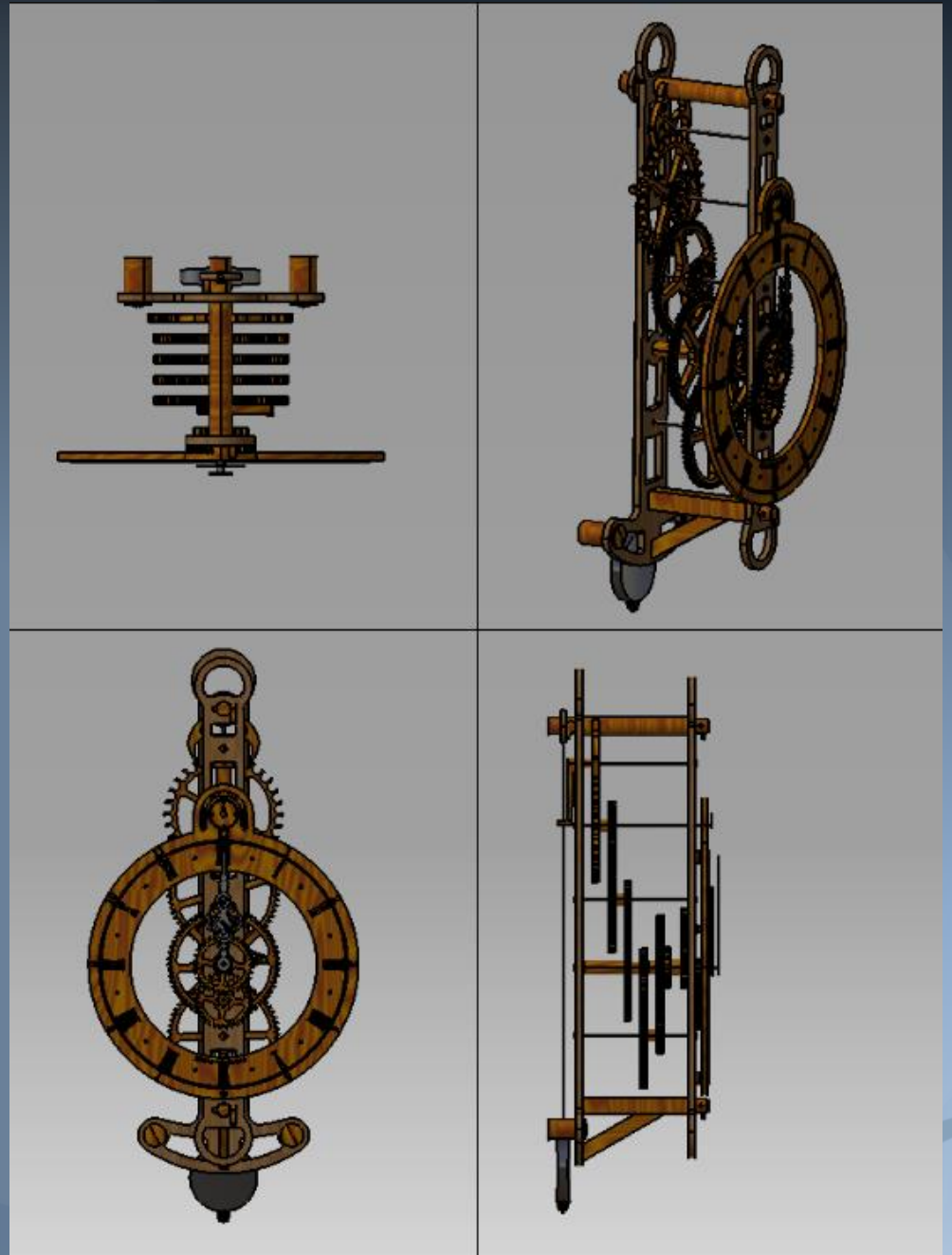
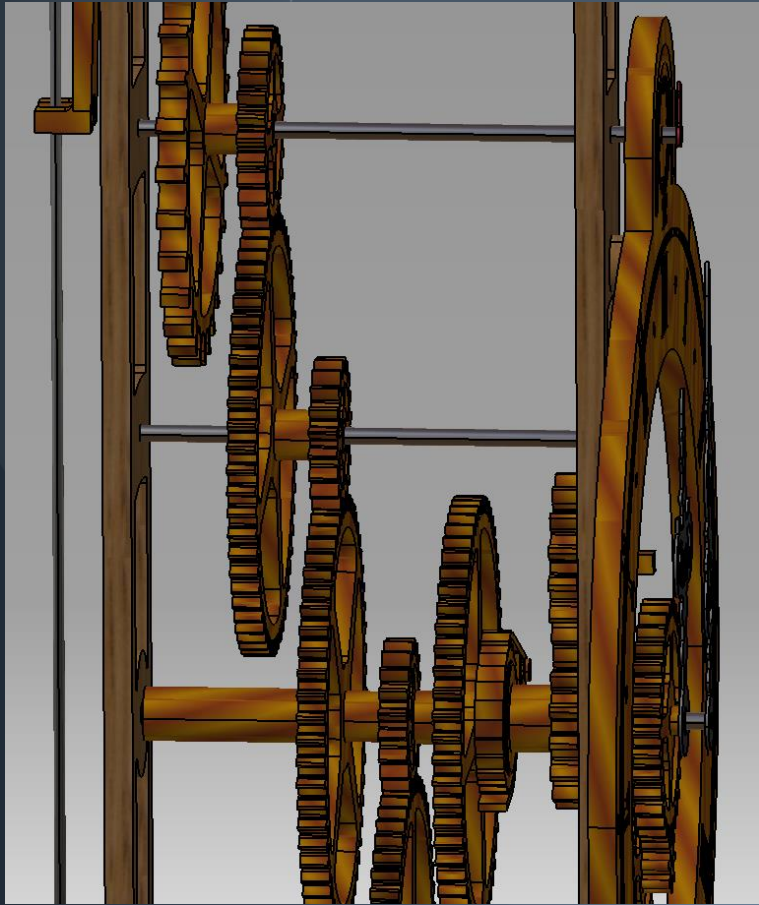

Video Link

- [Wooden Gear Clock 1/2](#)
- [Wooden Gear Clock 2/2](#)

Part Design



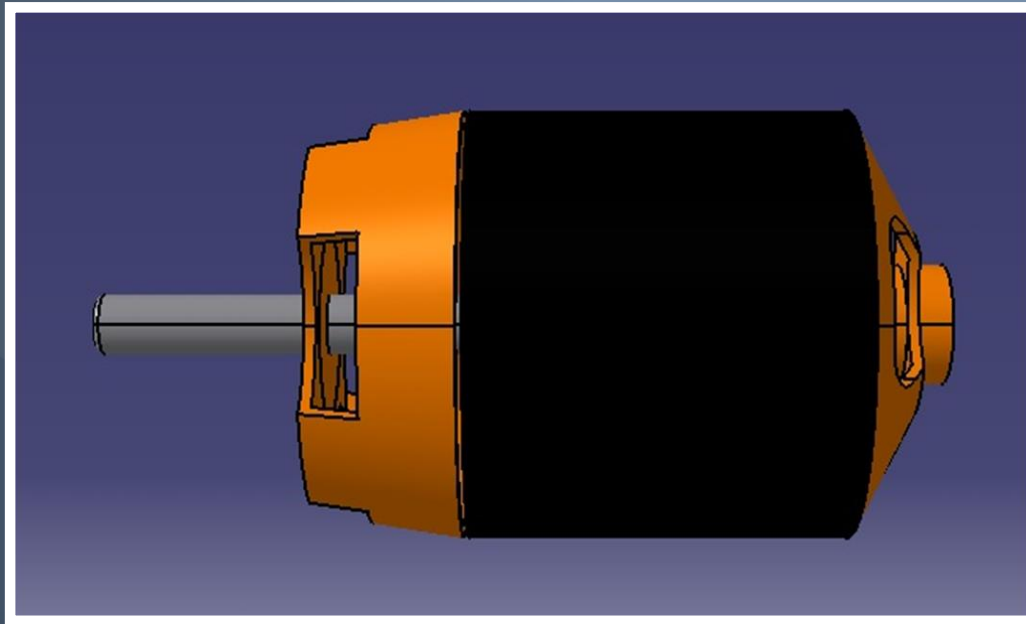
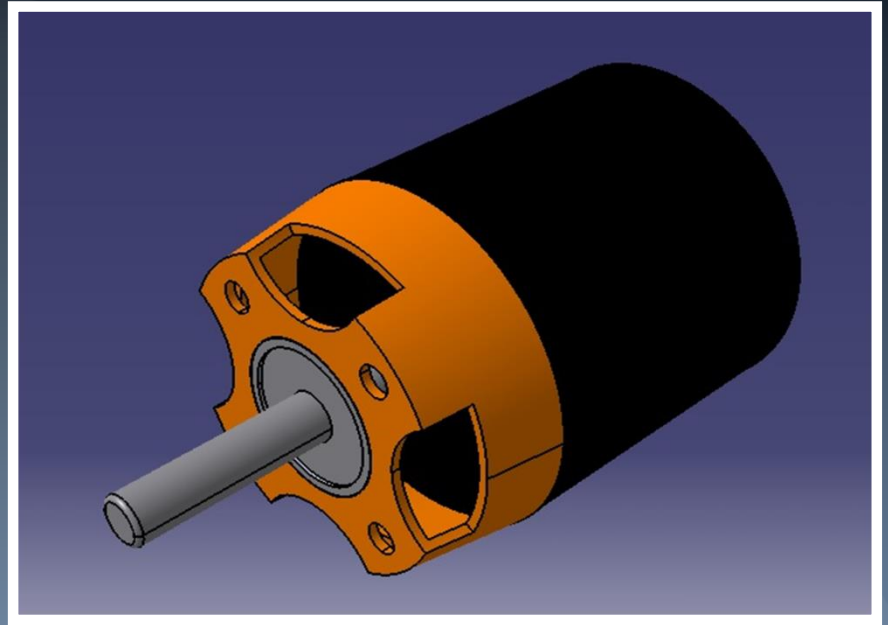
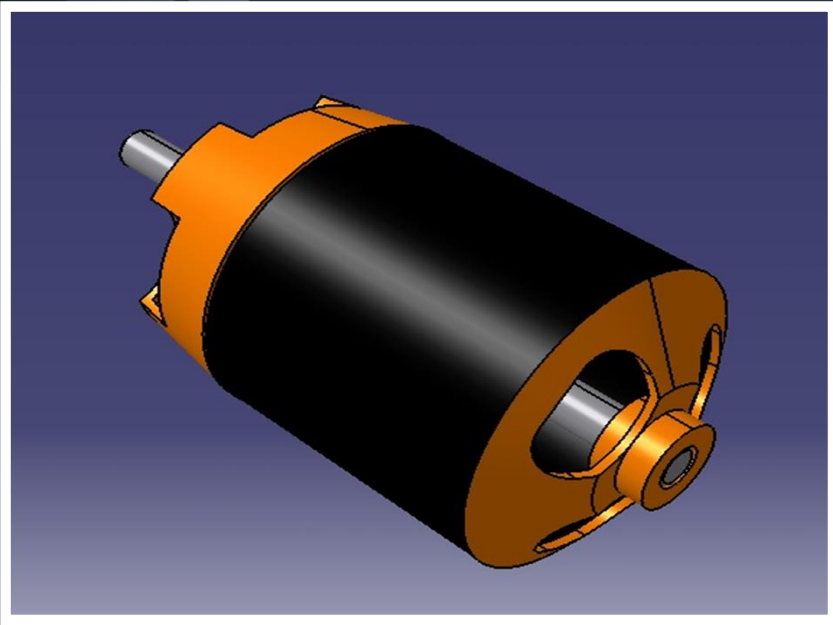

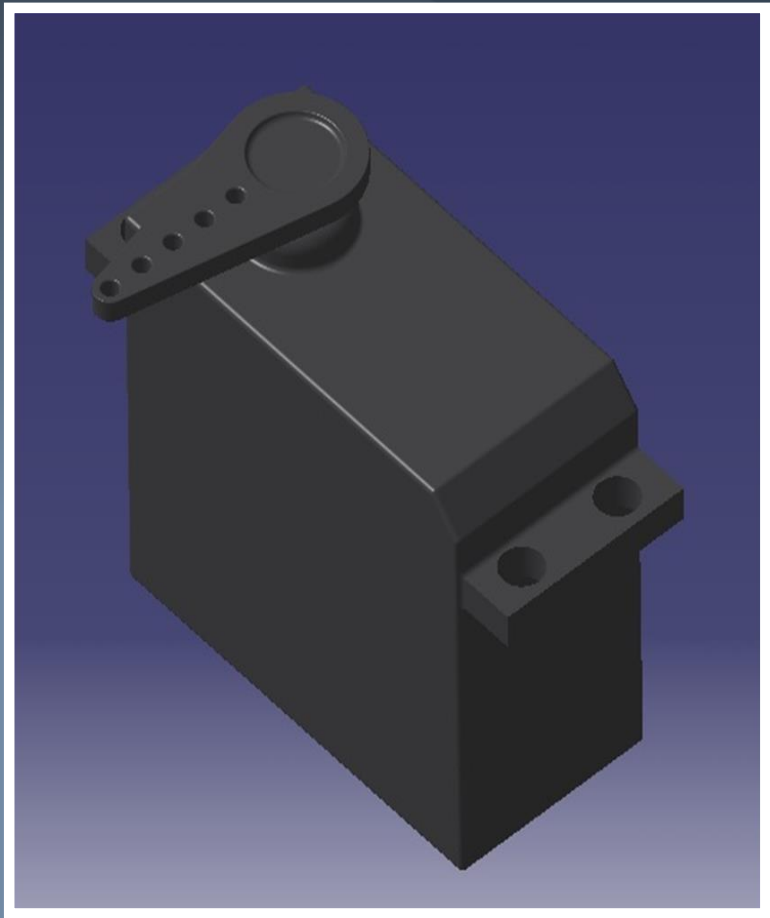
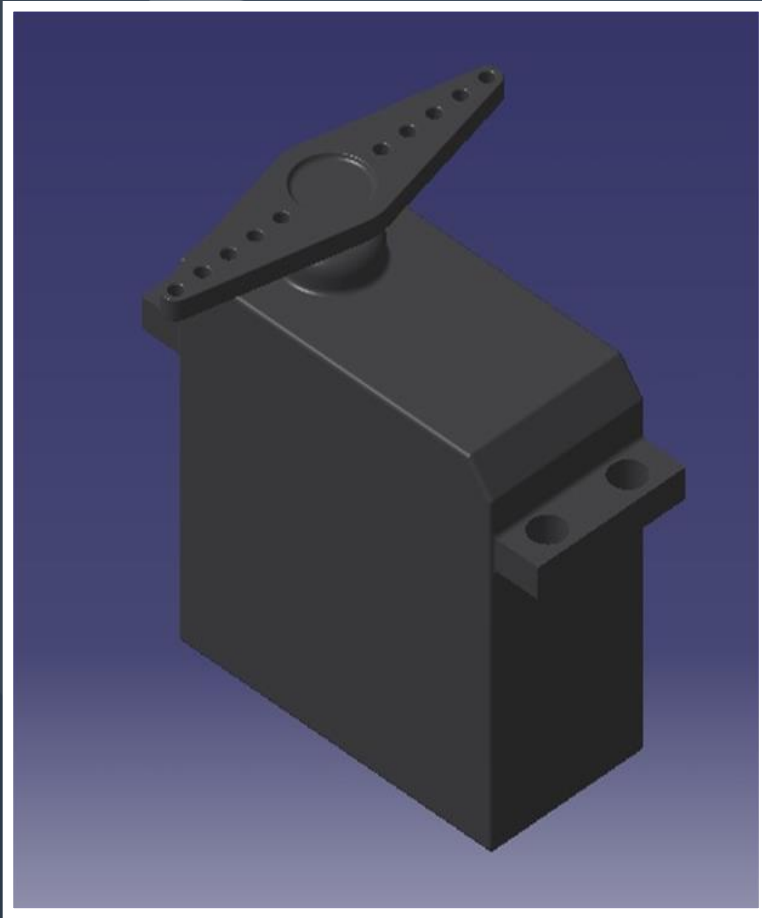

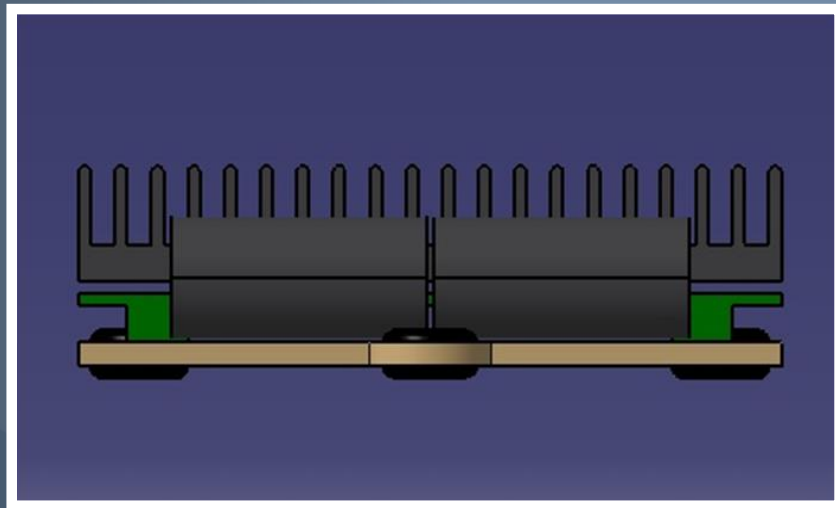
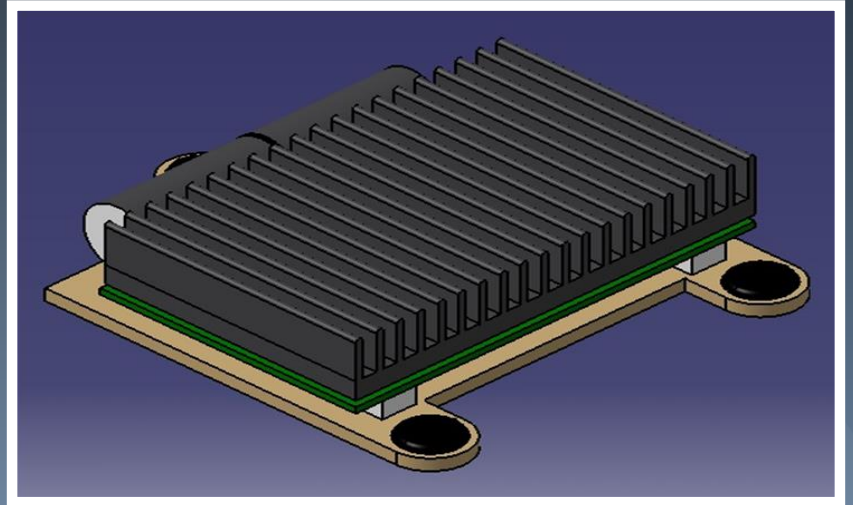
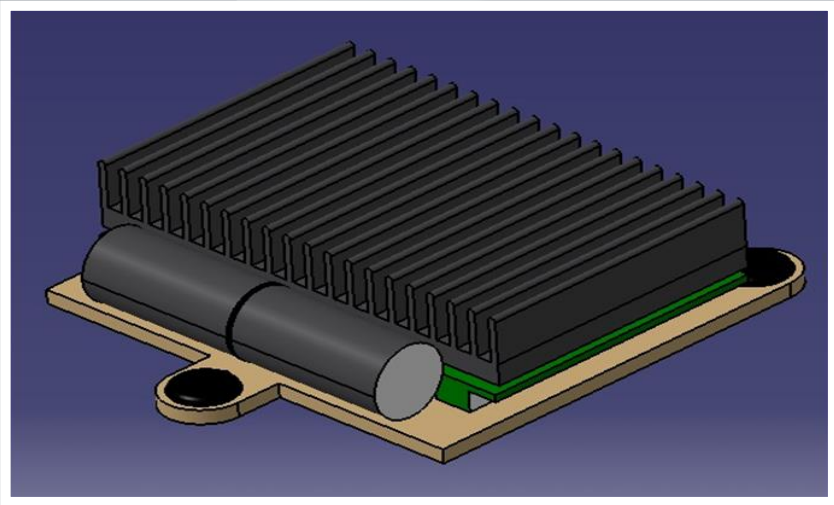

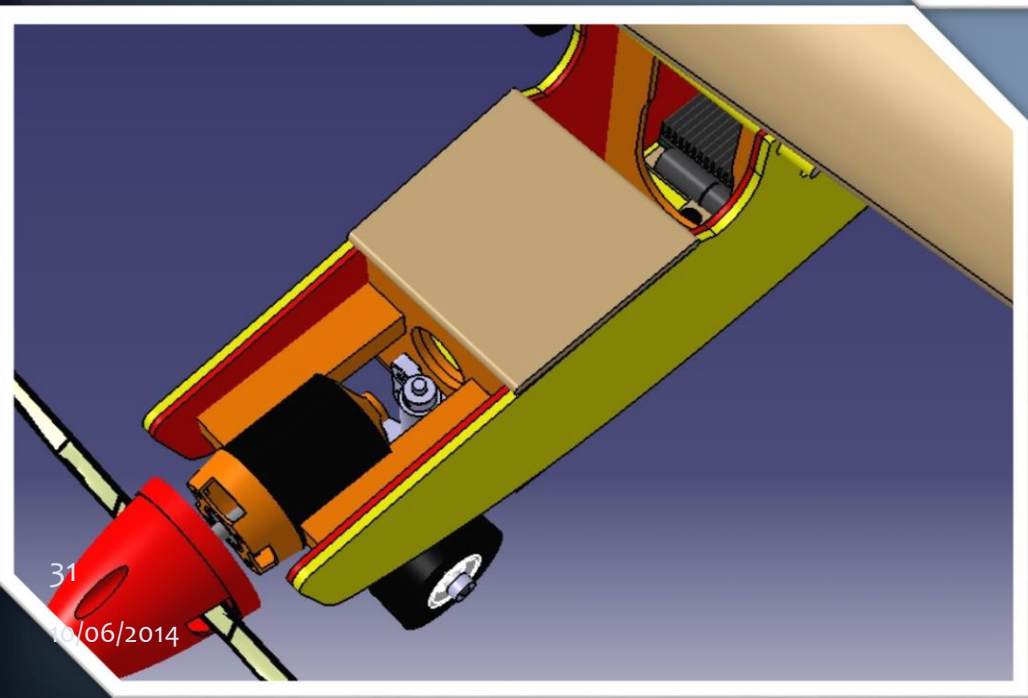
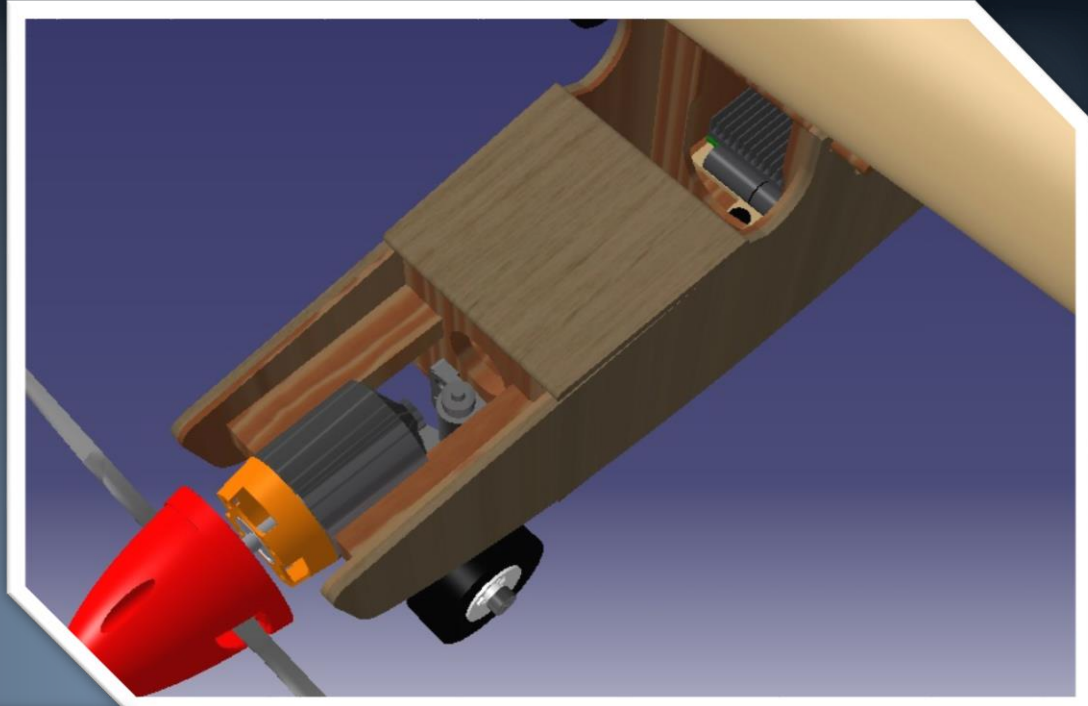

Drafting

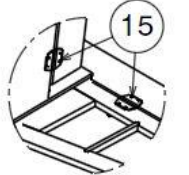
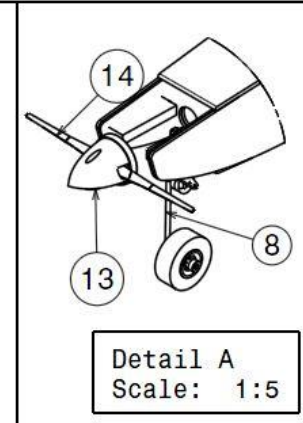
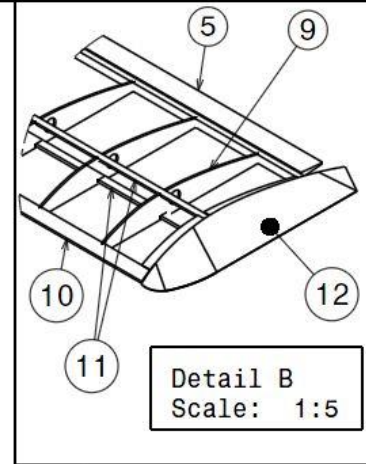
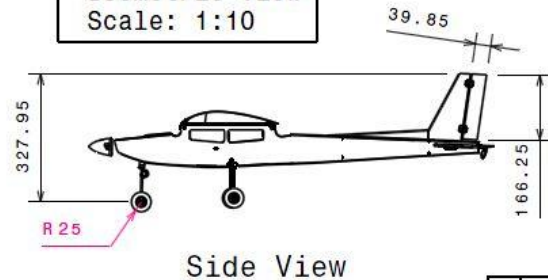
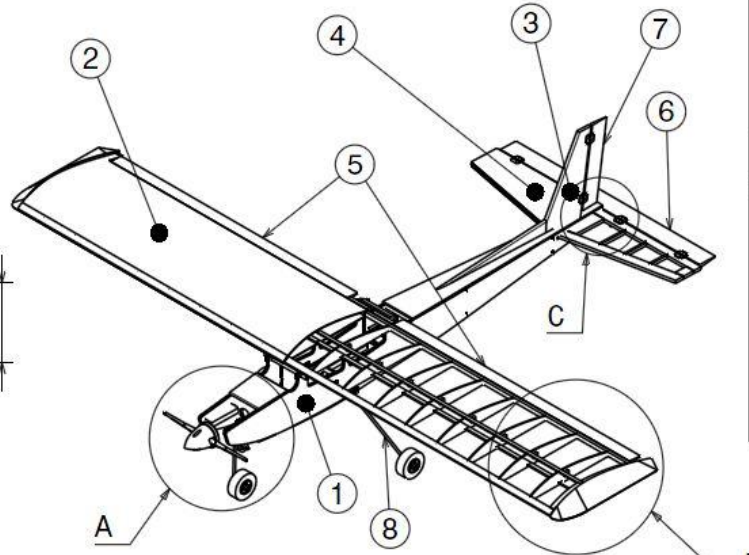
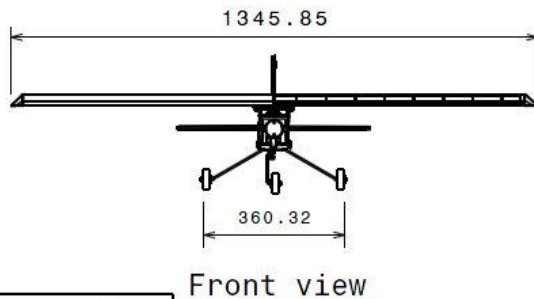
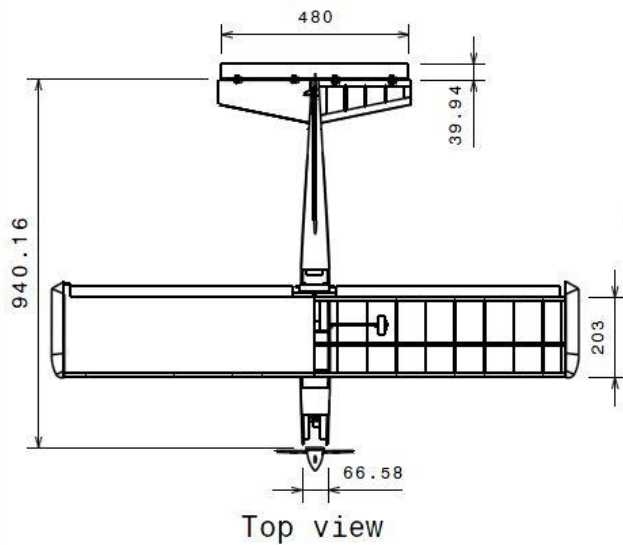

Detail C
Scale: 1:5

Surveillance Aircraft Assembly			
Part #	Part Name	Part #	Part Name
1	Fuselage	9	Airfoil
2	Wing	10	Airfoil Front Guide (Wing Front Support)
3	Vertical Stabilizer	11	Airfoil Middle Guide (Wing Middle Support)
4	Horizontal Stabilizer	12	Winglet
5	Ailerons	13	Propeller Cap
6	Elevator	14	Propeller
7	Rudder	15	Joint
8	Landing Gear		

PROPRIETARY INFORMATION NOT TO BE RELEASED WITHOUT WRITTEN AUTHORIZATION FROM CONCORDIA UNIVERSITY FINISH OTHER THAN SPECIFIED	MATERIAL	Balsa & Ply Wood		
	FINISH	Sanded	CONCORDIA UNIVERSITY	
	ALL DIMENSIONS IN	mm	DESIGNED	Team Number 17
	SURFACE ROUGHNESS	√XX	CHECKED	
	TOLERANCES	X - 2 mm .X - .?? .XX - .??? .XXX - .???	APPROVED	
ANGLE	2	DATE	DEC 15, 2009	
?	TITLE	Surveillance Aircraft		
SCALE	1:15	SHEET	1 of 5	
		USED ON	Capstone Project	
		DWG NO		
		REV		

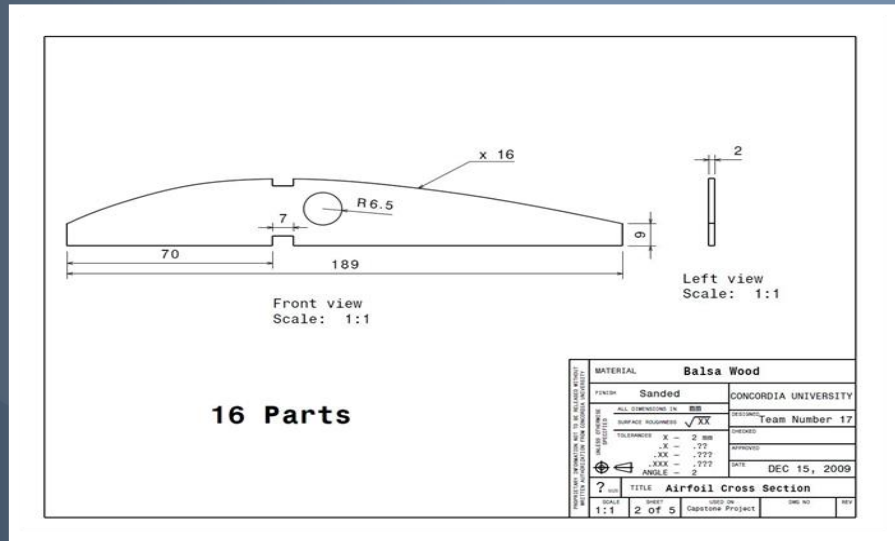
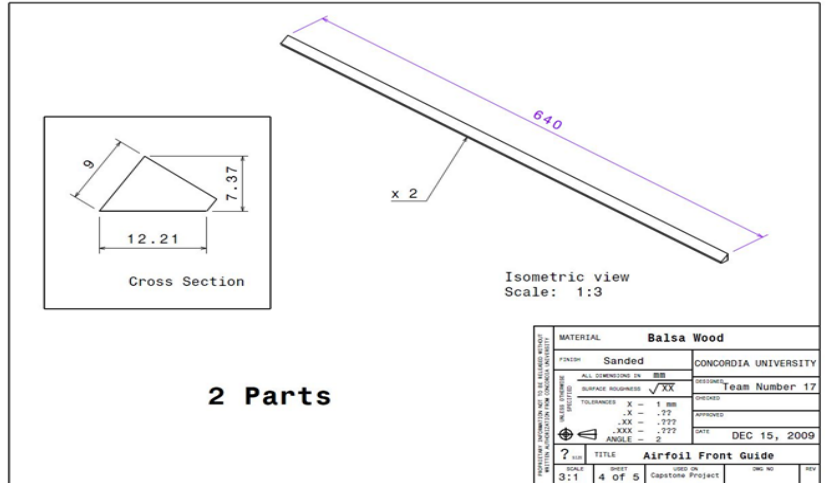
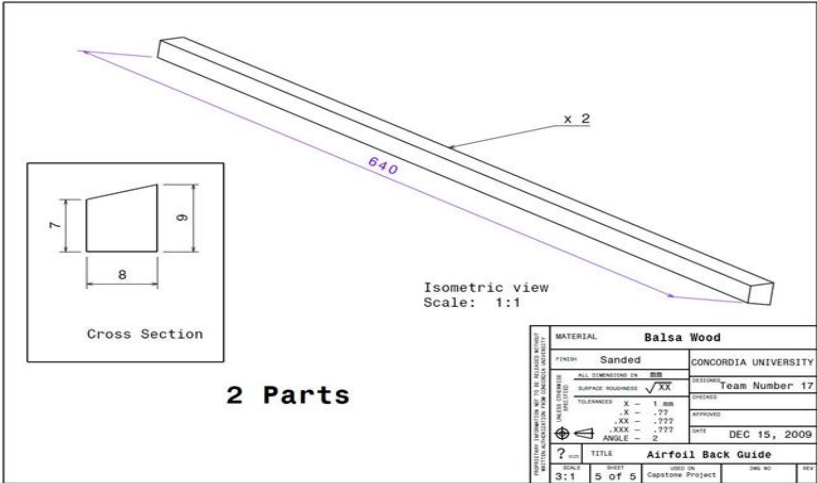

Static Analysis

Static Case Solution.1 - Deformed Mesh.1



Static Case Solution.1 - Von Mises Stress (nodal values).2

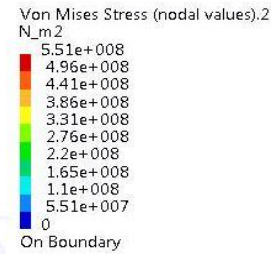

Static Case Solution.1 - Deformed Mesh.2



Static Case Solution.1 - Von Mises Stress (nodal values).2

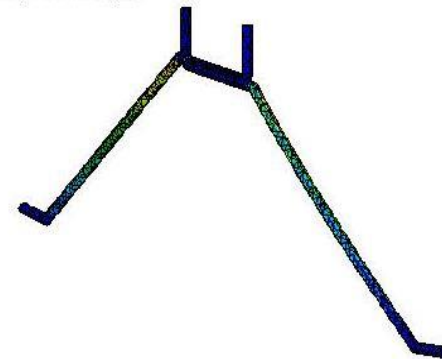
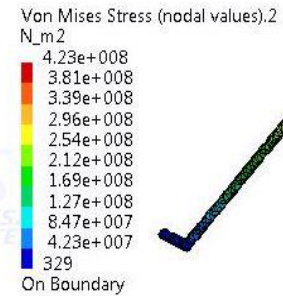

Video Link

- [Plane Project – Capstone](#)
- [Gears Simulation](#)
- [Animation Constrains](#)

SolidWorks 2010

Assembly Design



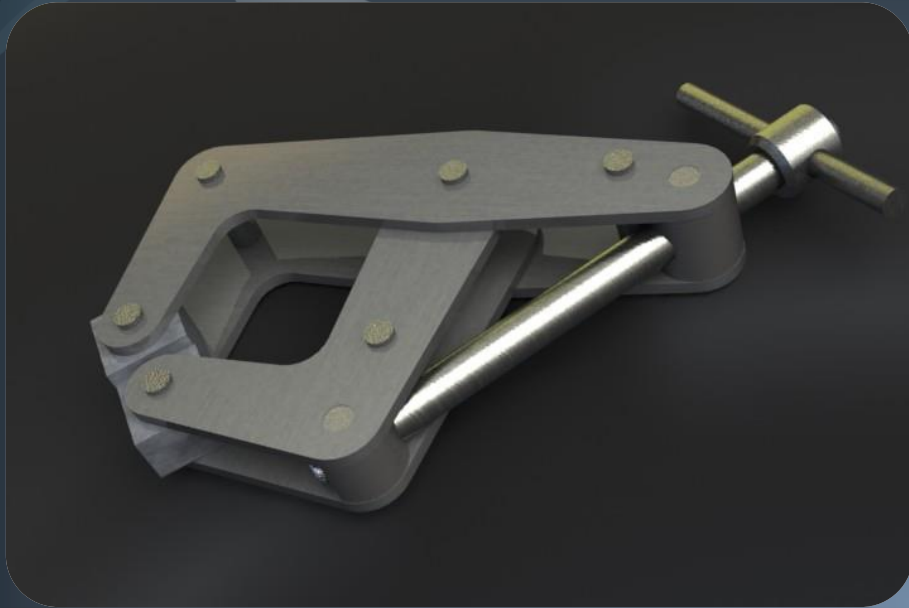





FloXpress Analysis Wizard

NACA-64~1

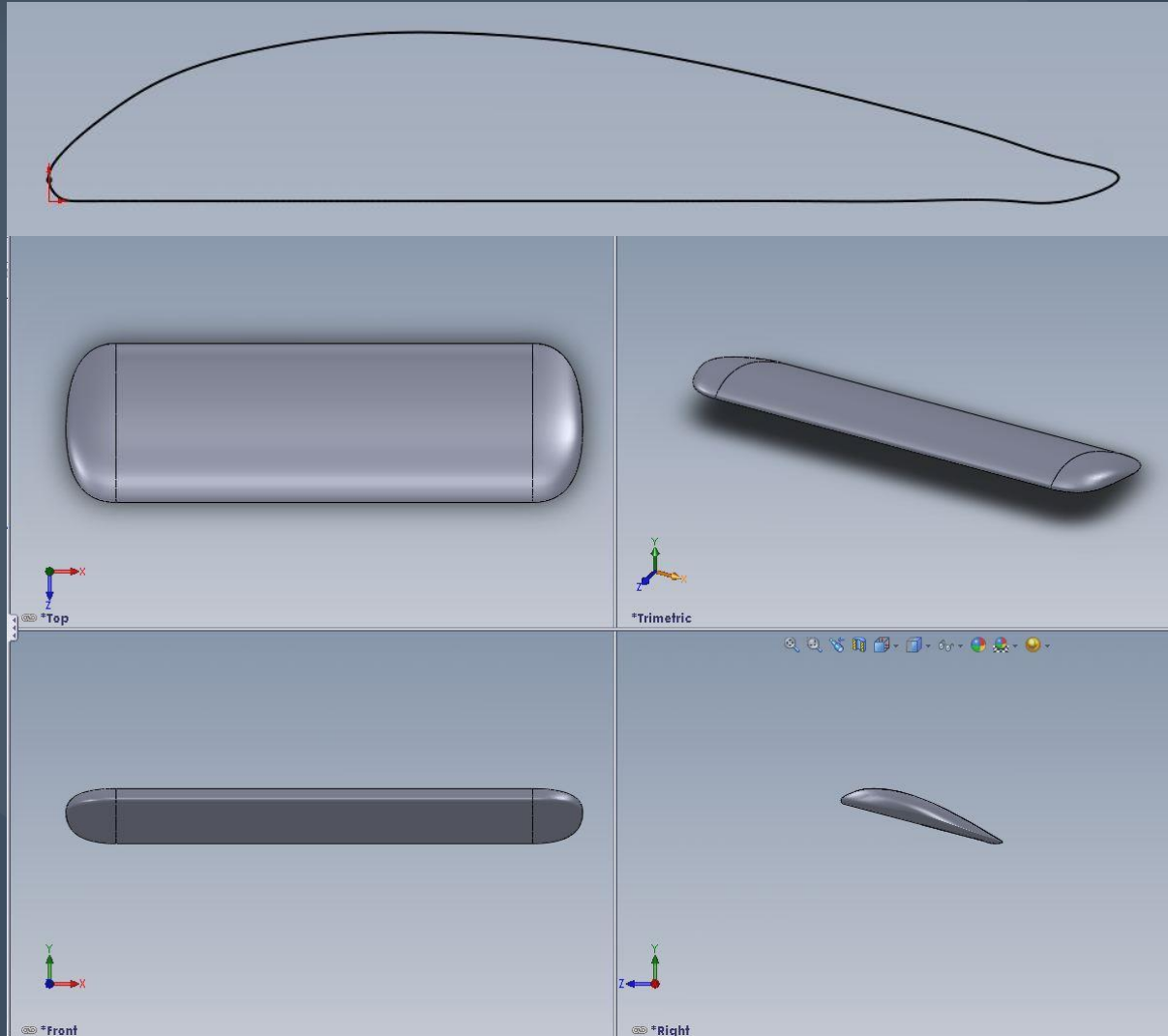

Zero Degree Angle of Incidence

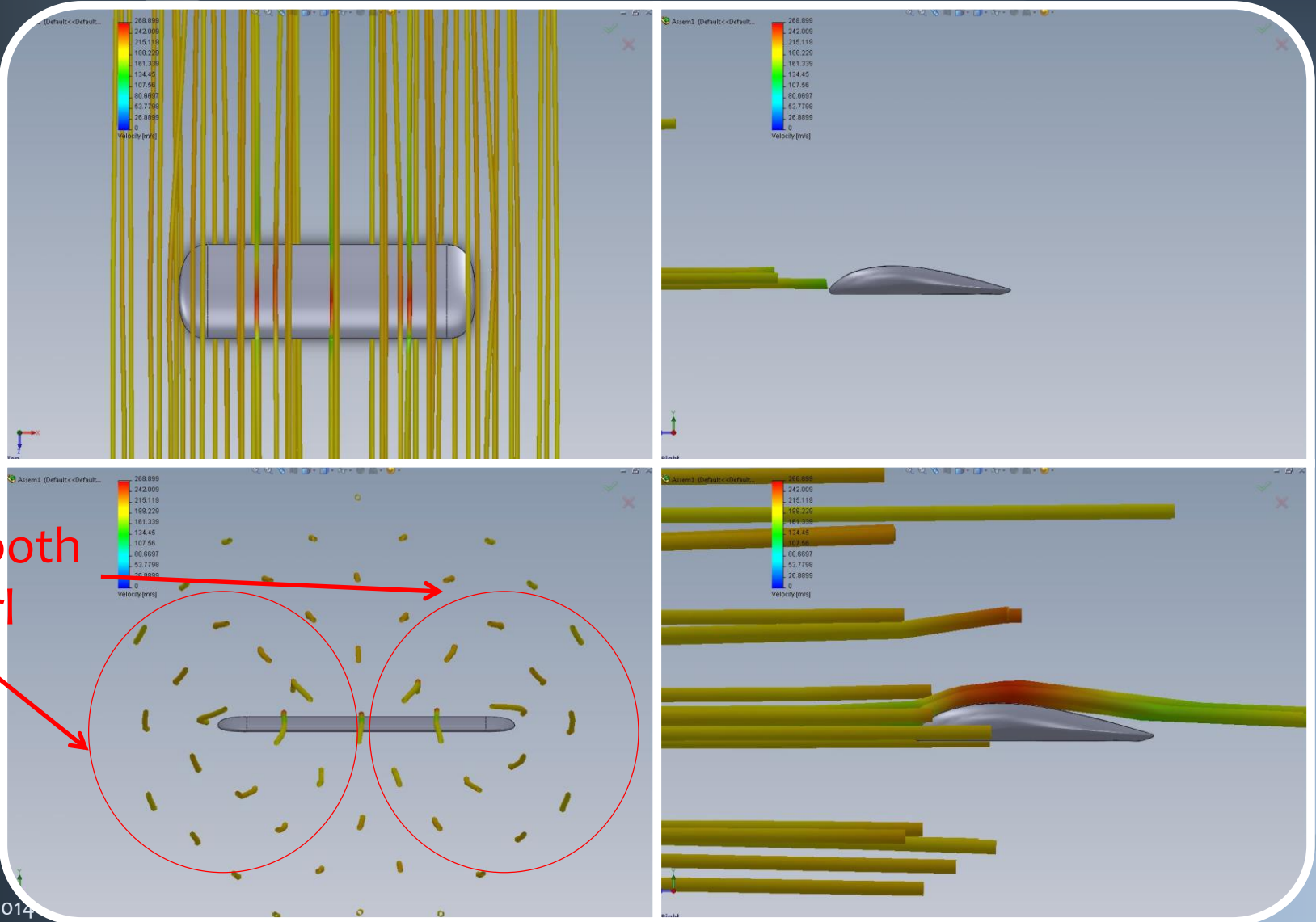

Smooth Swirl

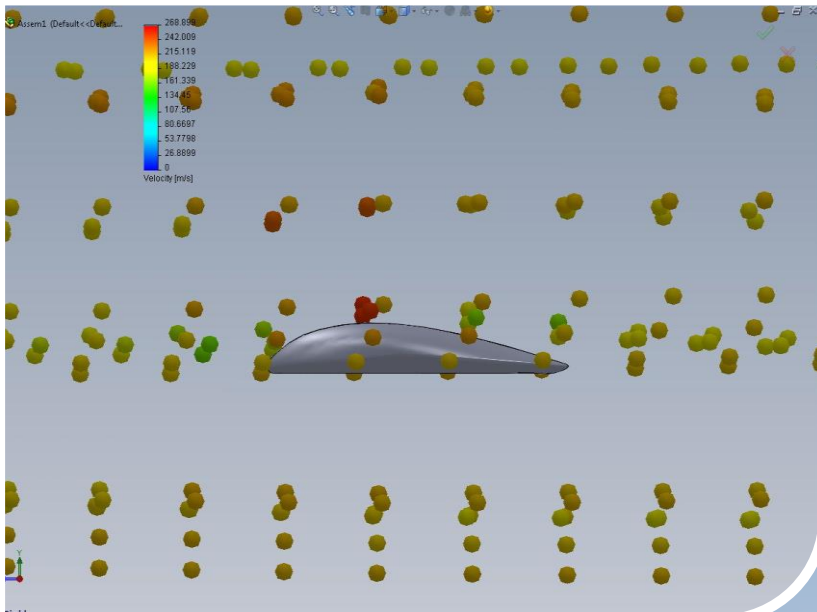
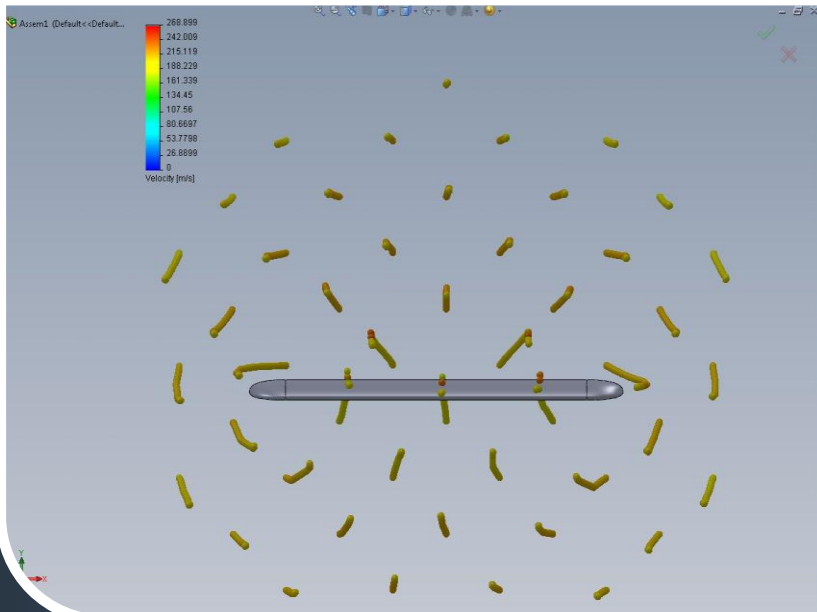
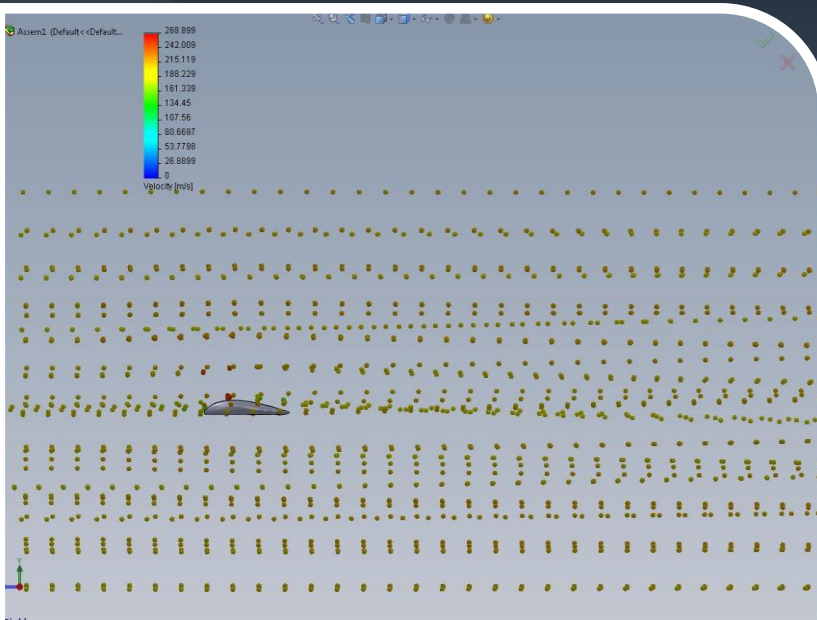
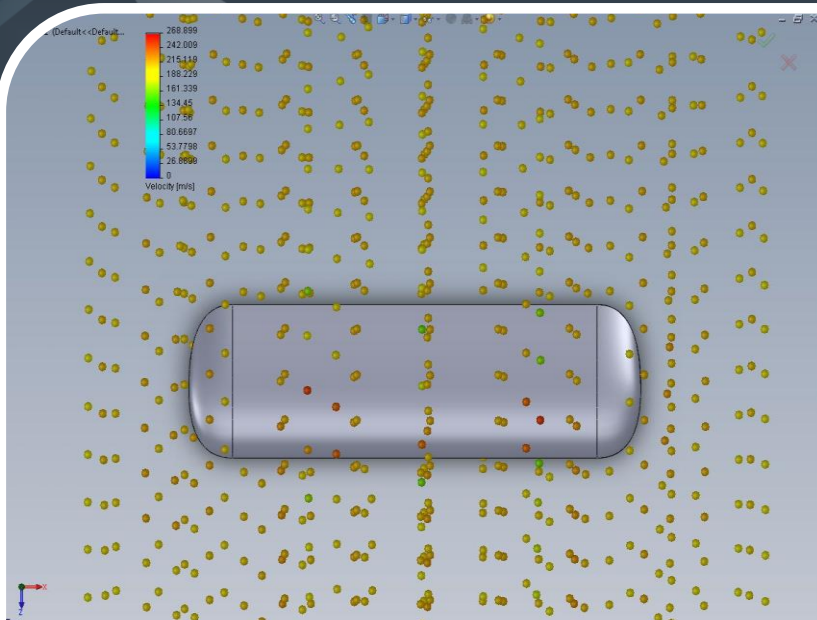

15 Degrees Angle of Incidence

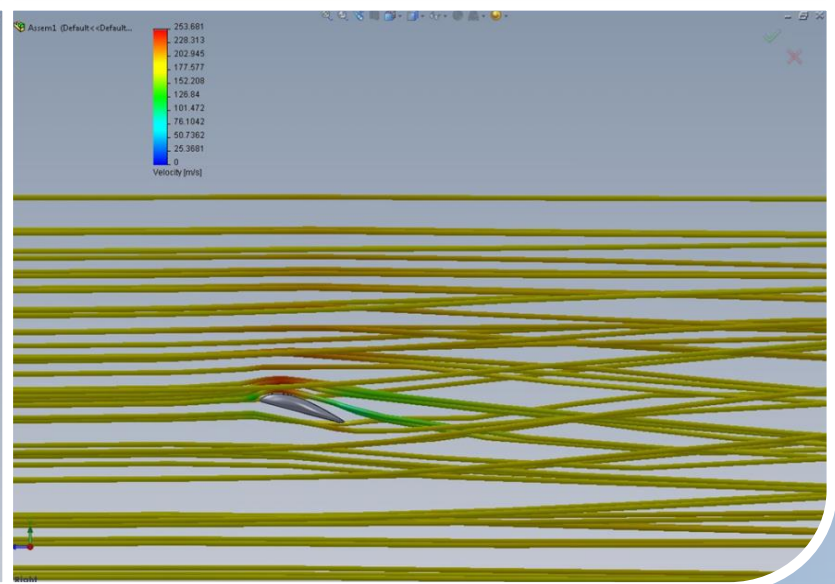
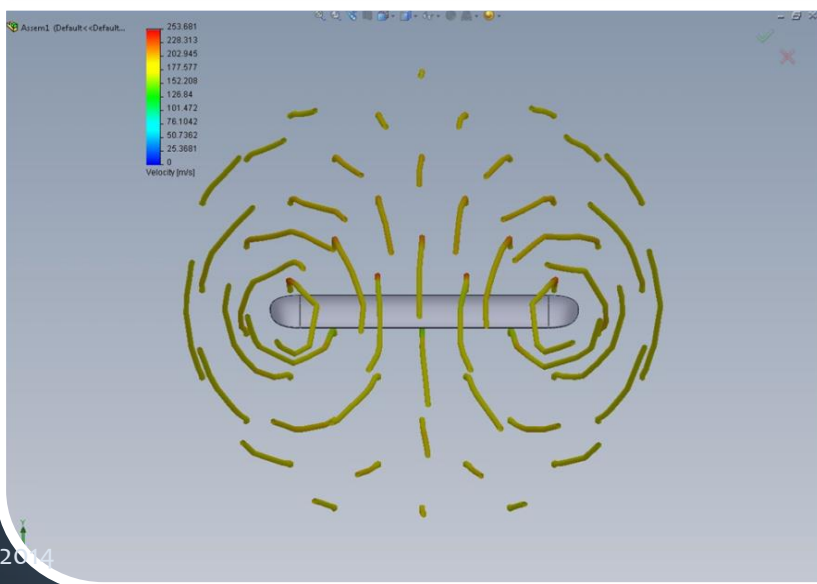
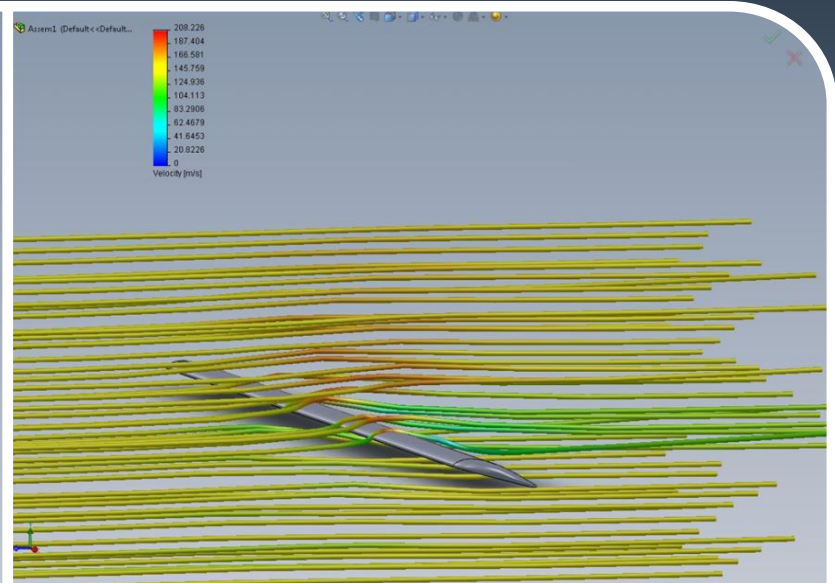
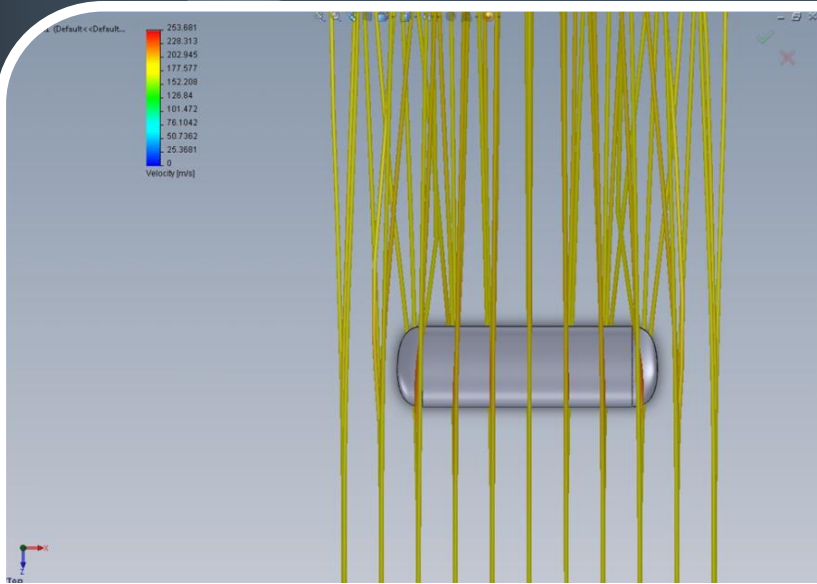

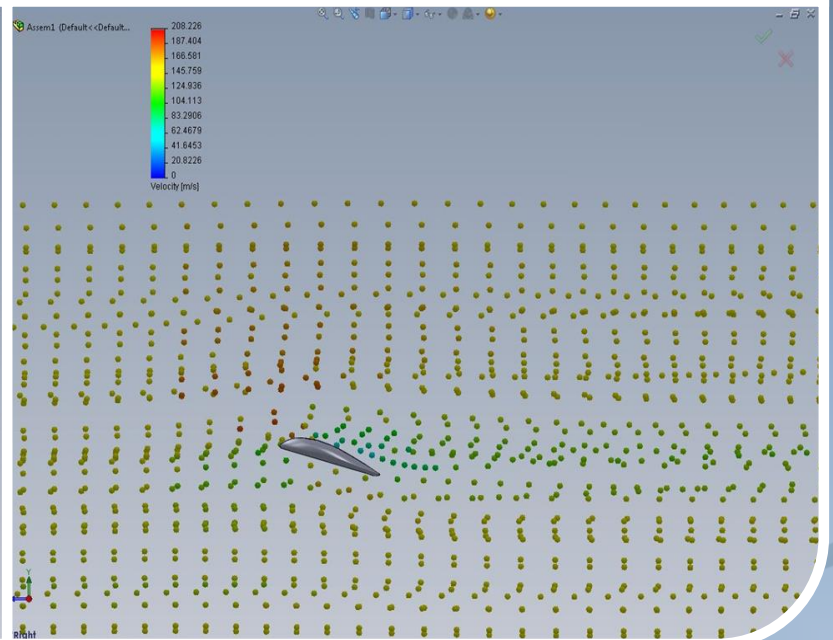
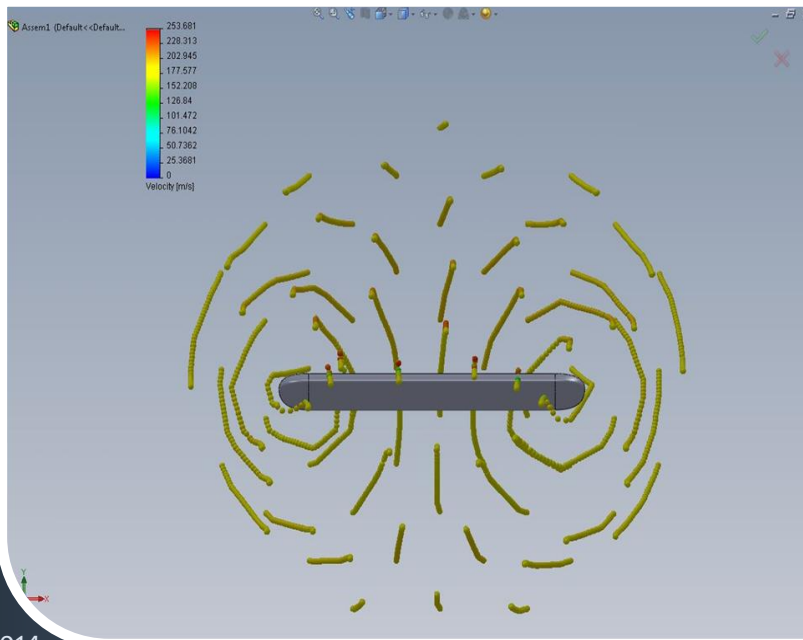
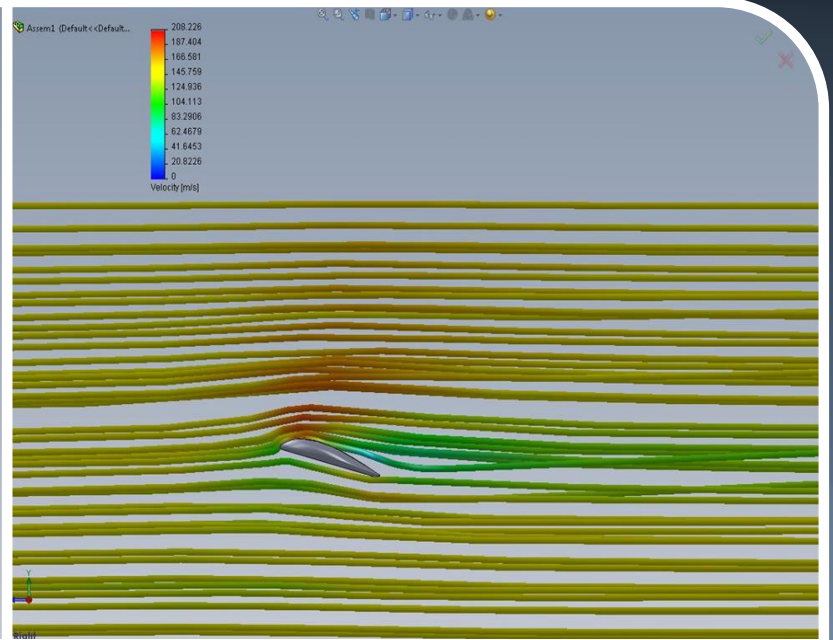
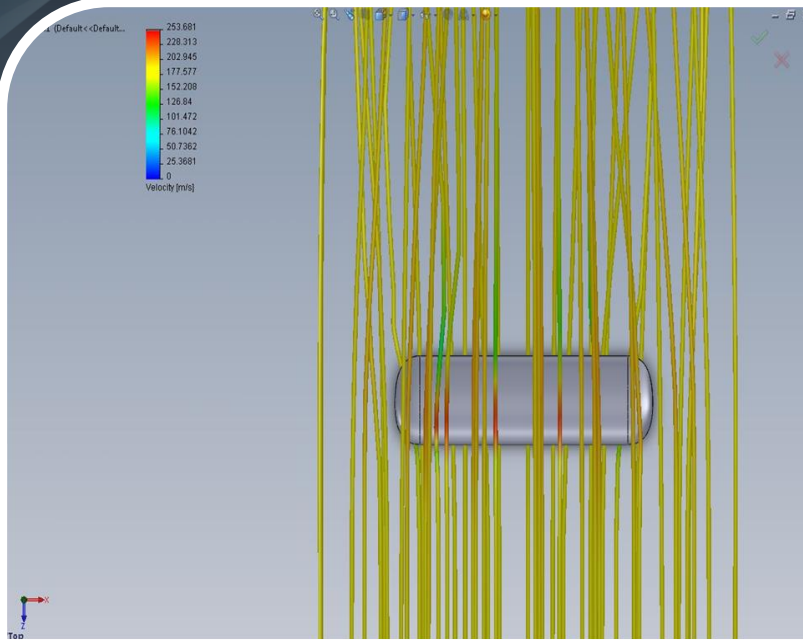

30 Degrees Angle of Incidence

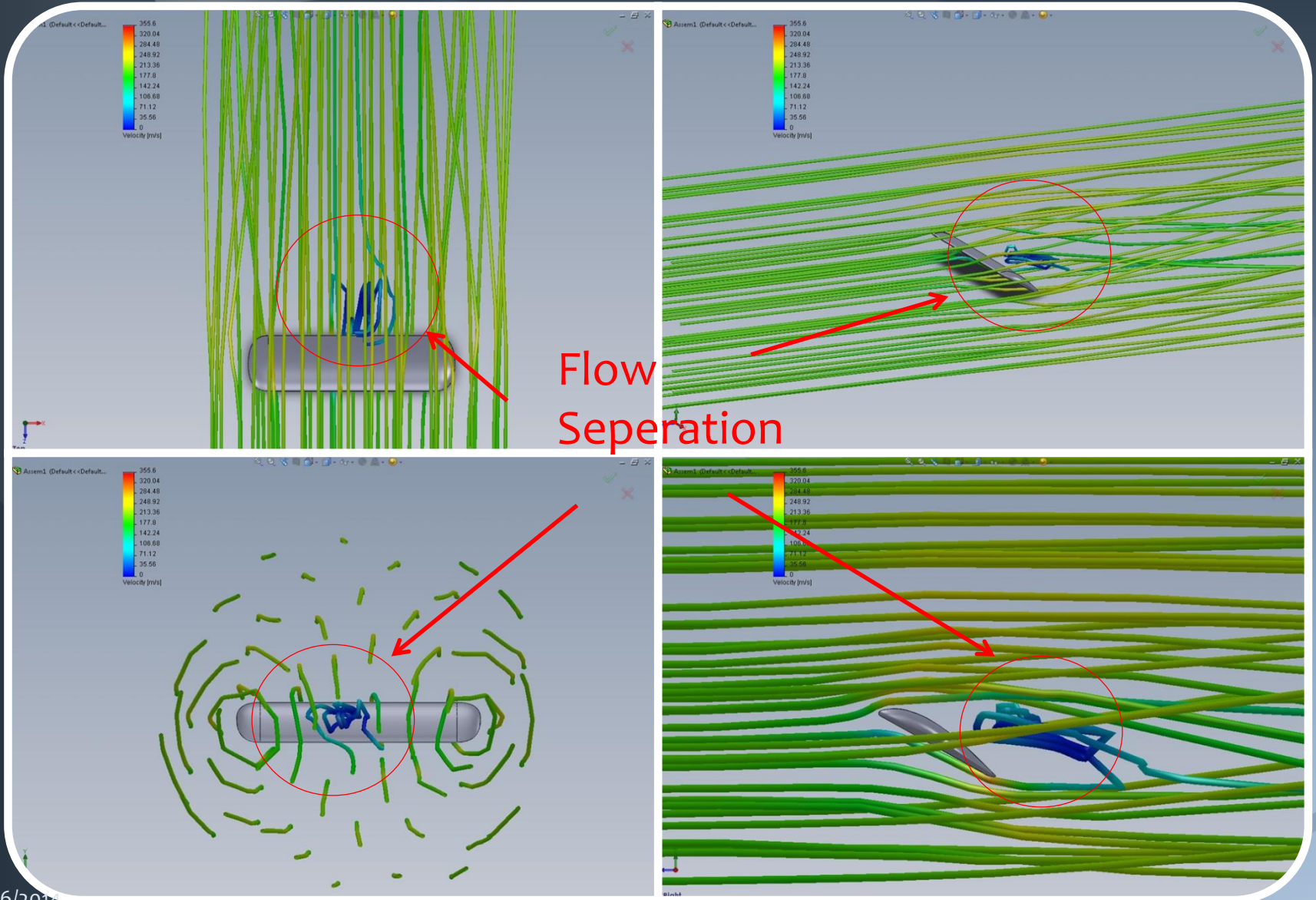

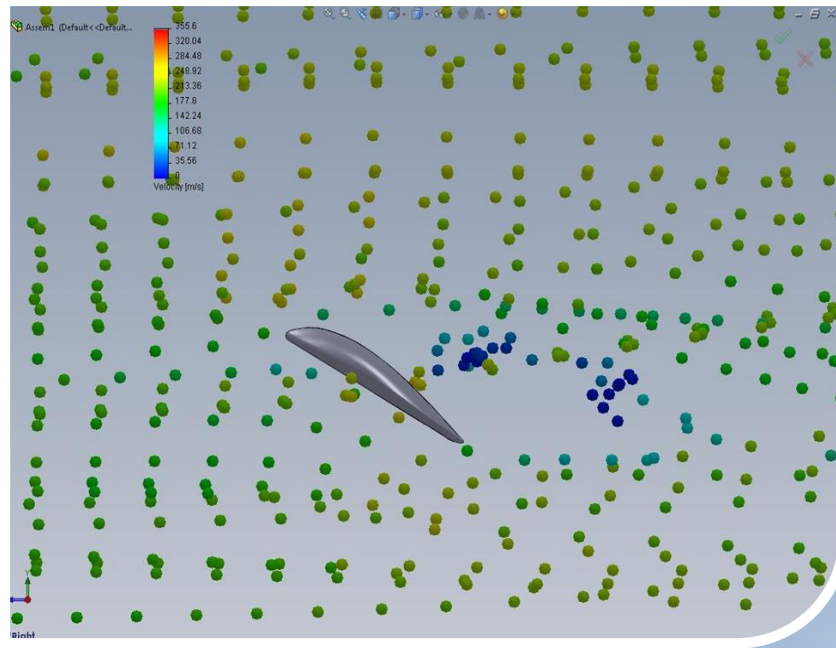
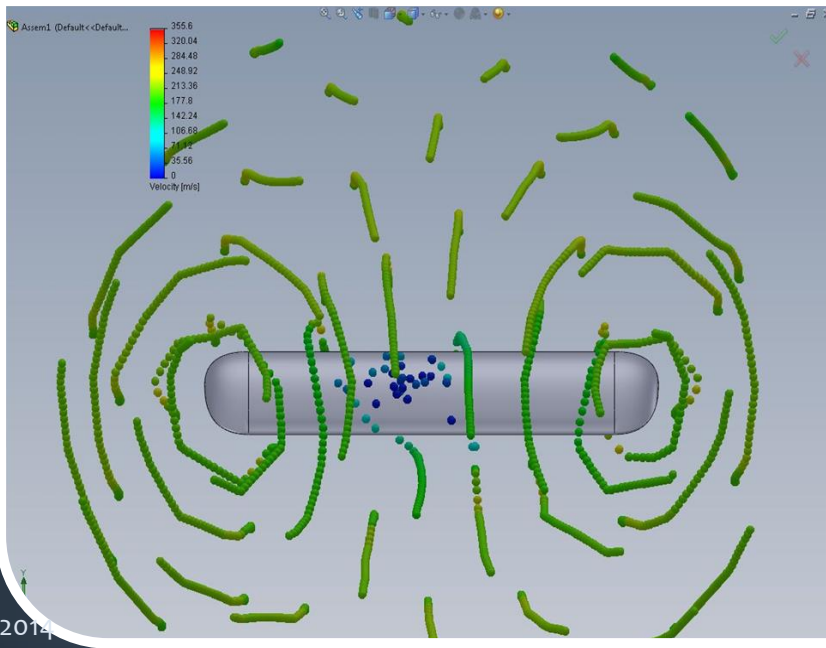
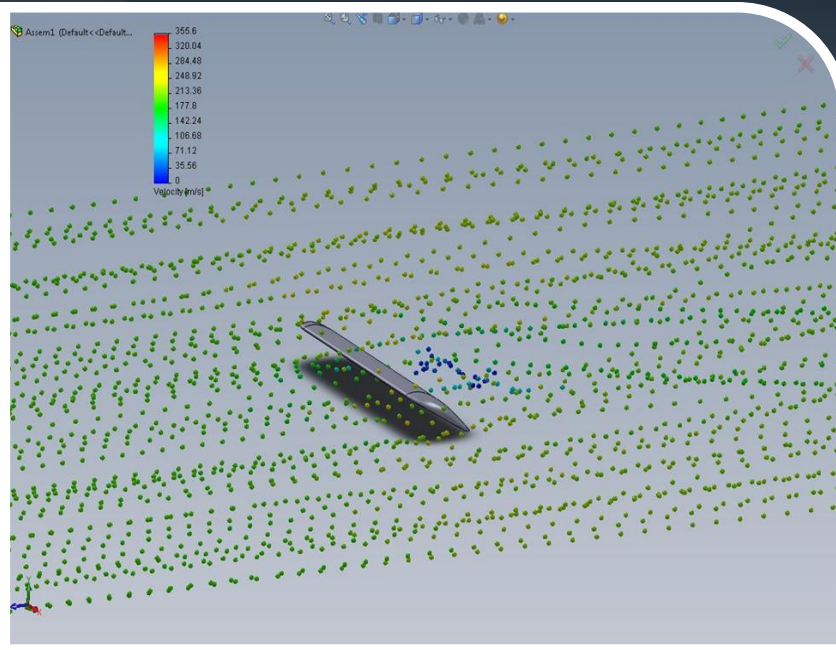
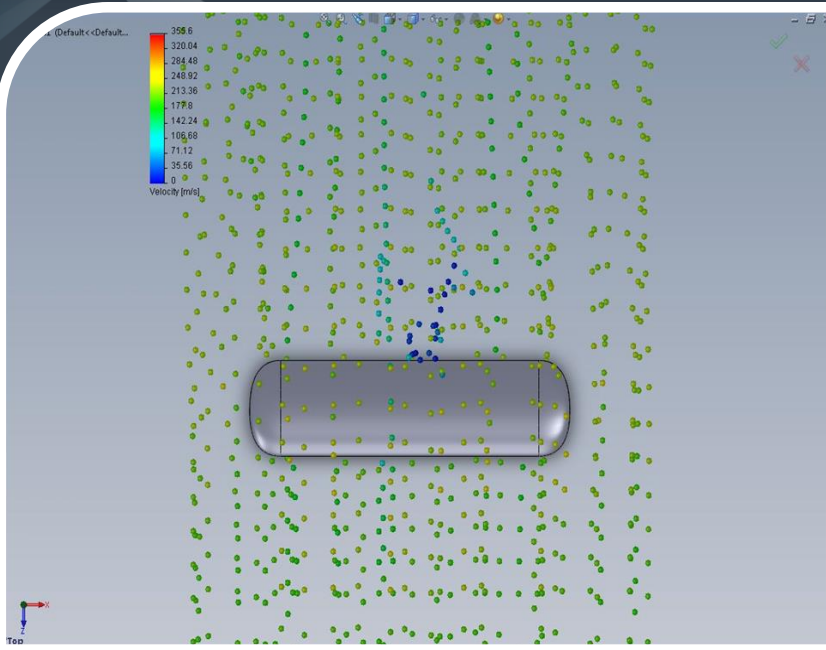

Sink

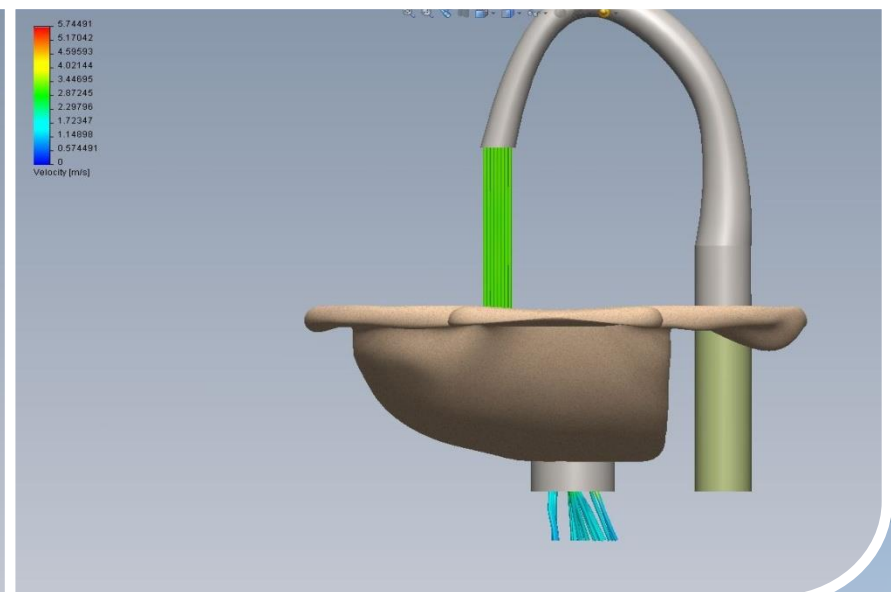
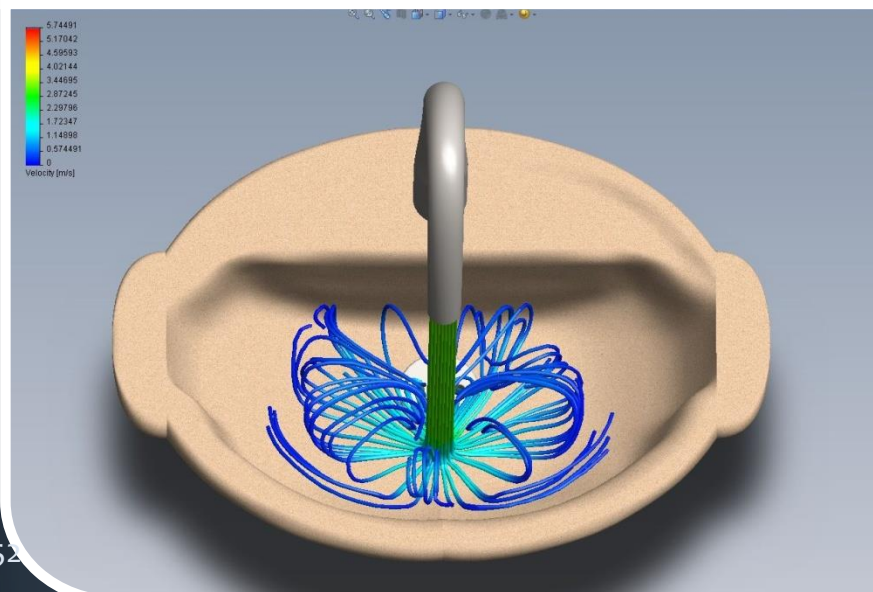
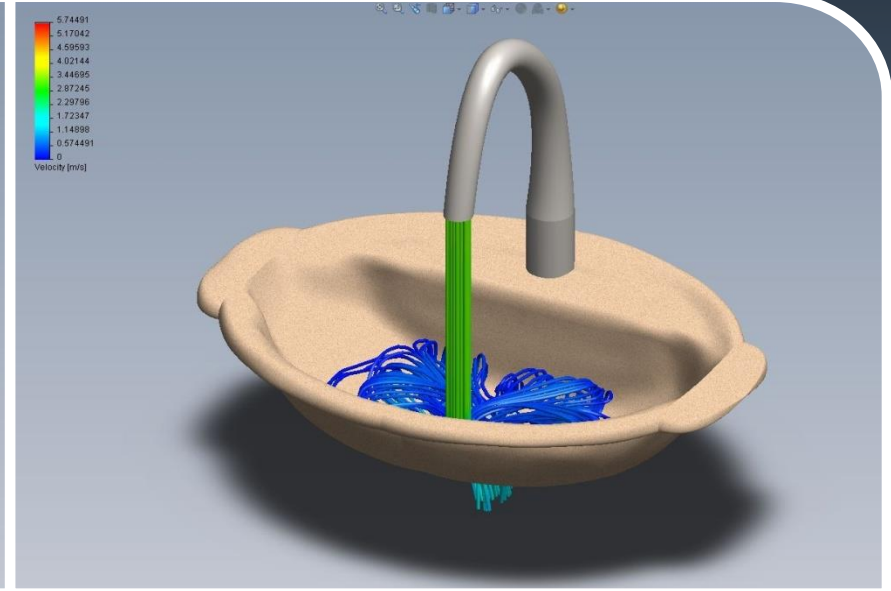
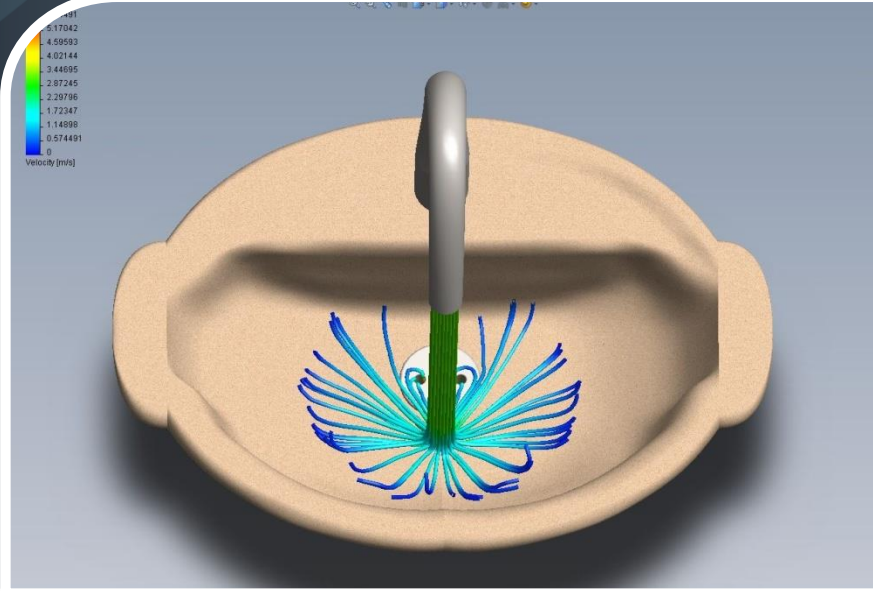

Flow Simulation

Shear Stress on Airfoil surface (NACA-64~1)

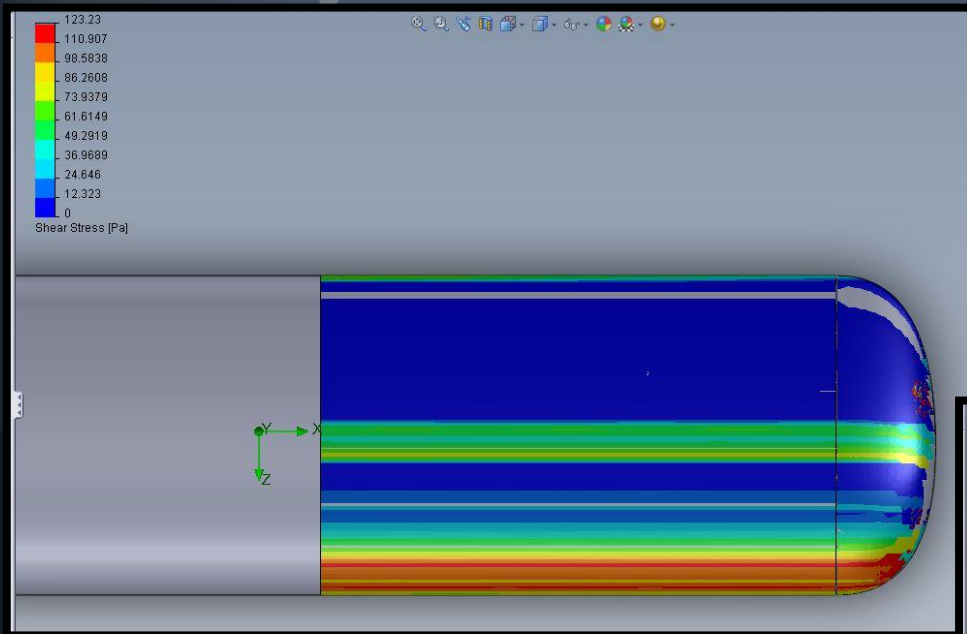

Top View

Bottom View

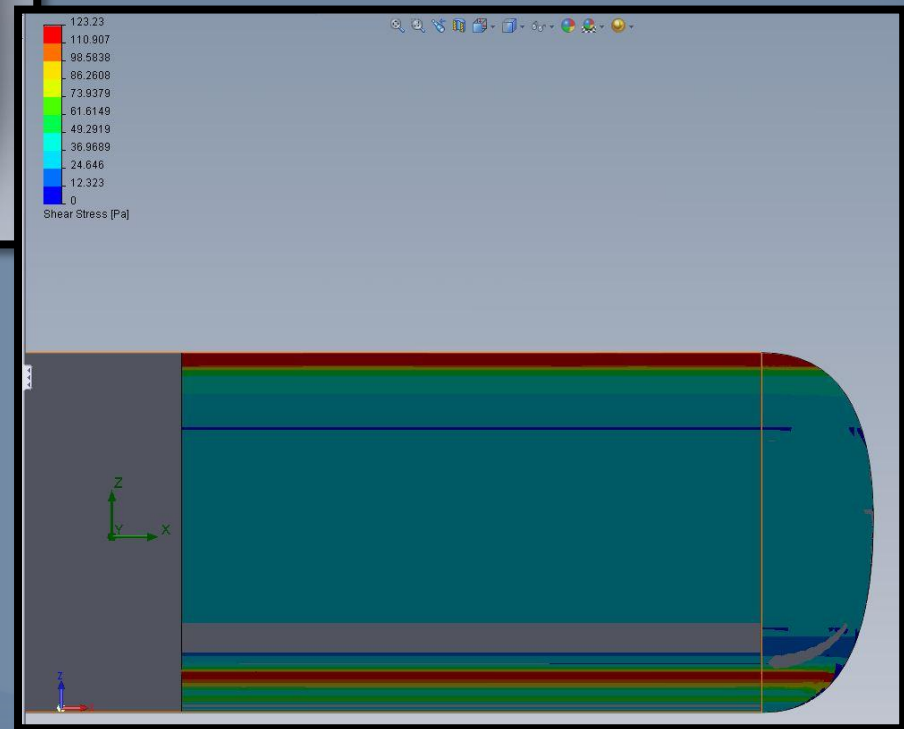

Mach Number

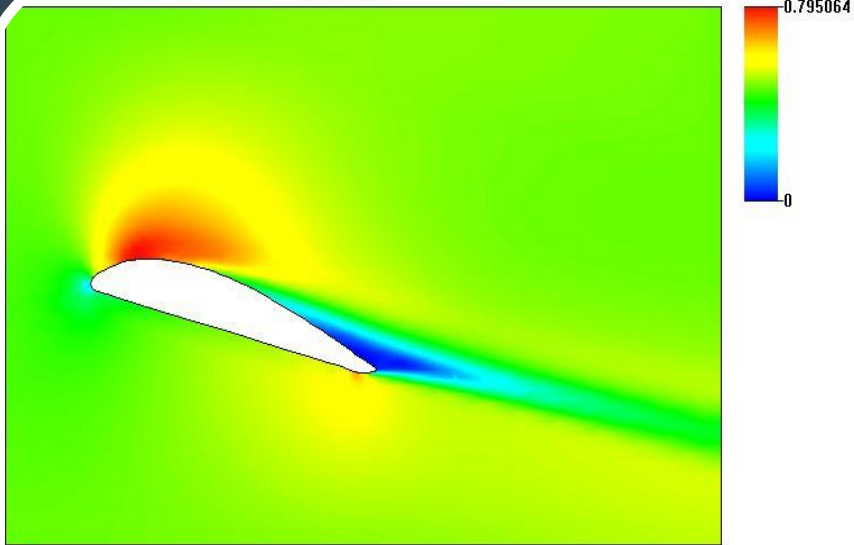

Min=0 Max=0.795064
Time = 0.00613433692 s

Pressure [Pa]

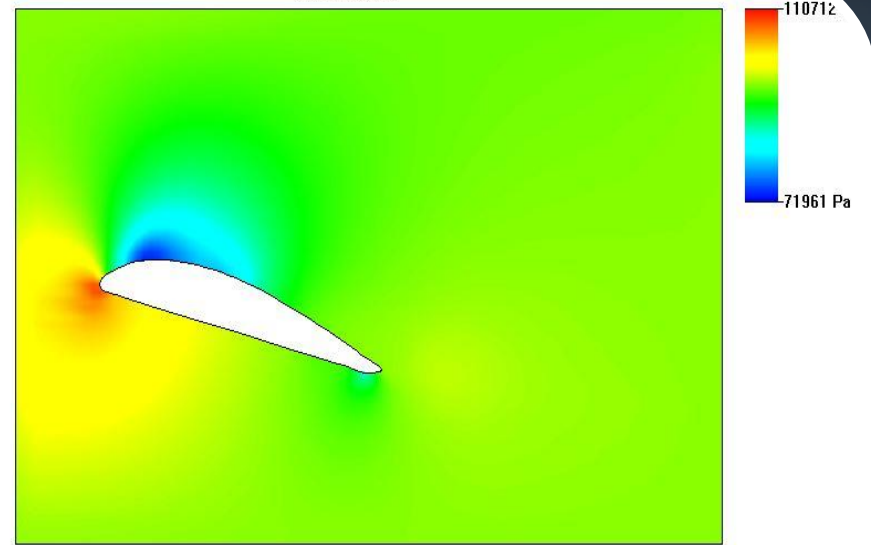

Min=-71961 Pa Max=110712 Pa
Time = 0.00283437598 s

Temperature [K]

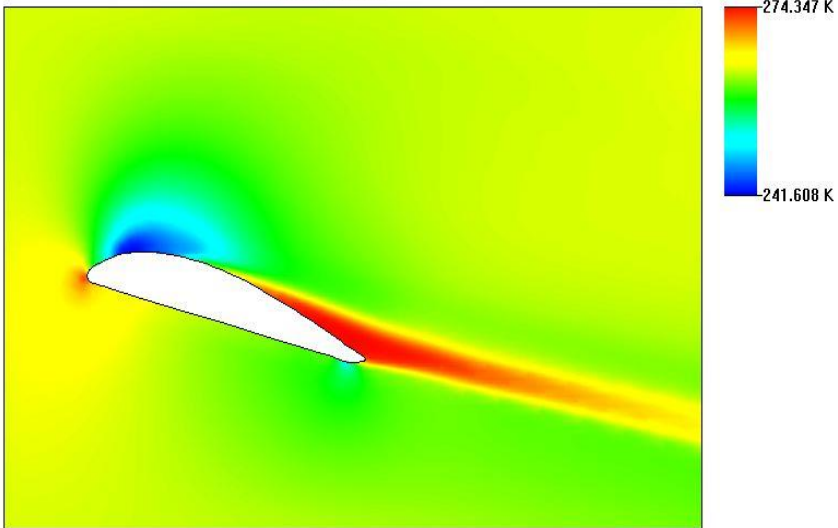

Min=241.608 K Max=274.347 K
Time = 0.00672951314 s

Velocity [m/s]

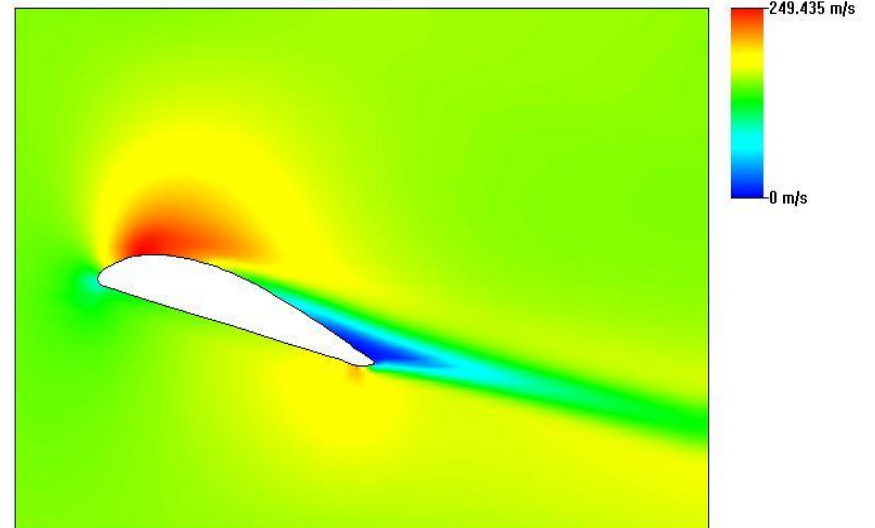

Min=0 m/s Max=249.435 m/s
Time = 0.00517263917 s

Compressor Blade (Analysis at r_{ava})

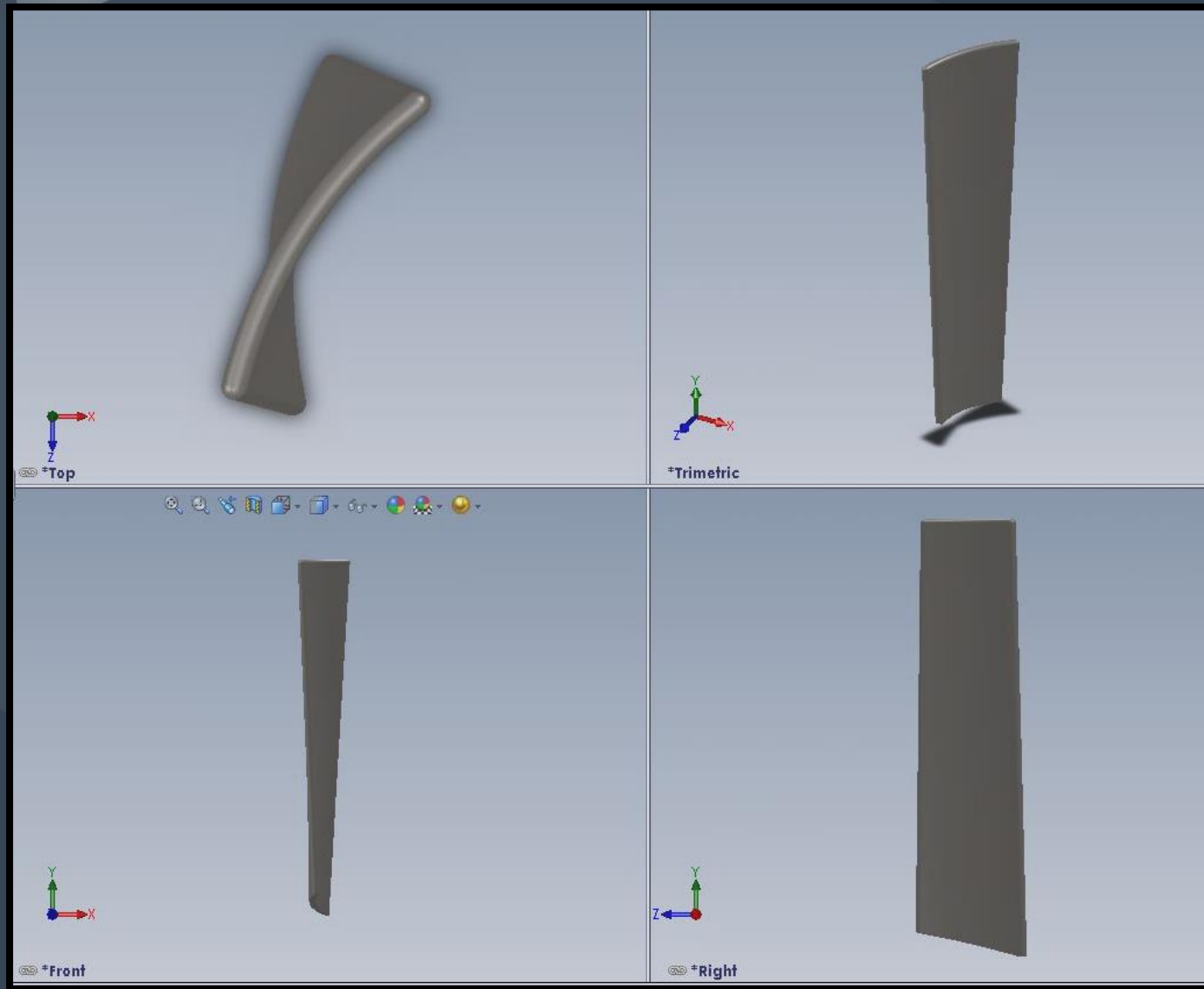

Mach Number

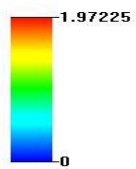
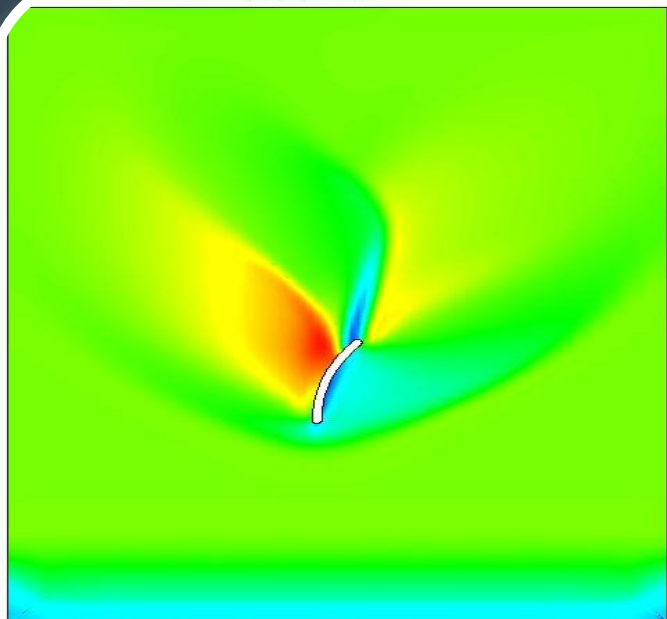

Pressure [Pa]

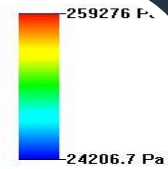
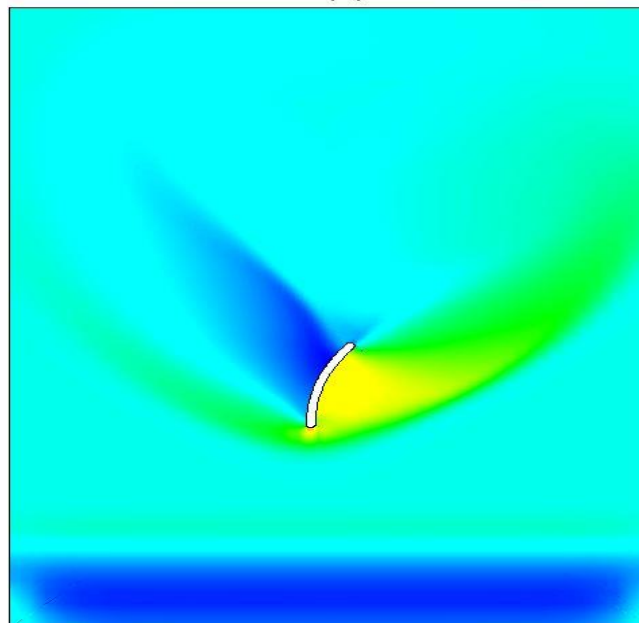

Velocity [m/s]

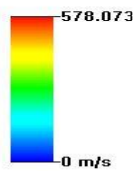
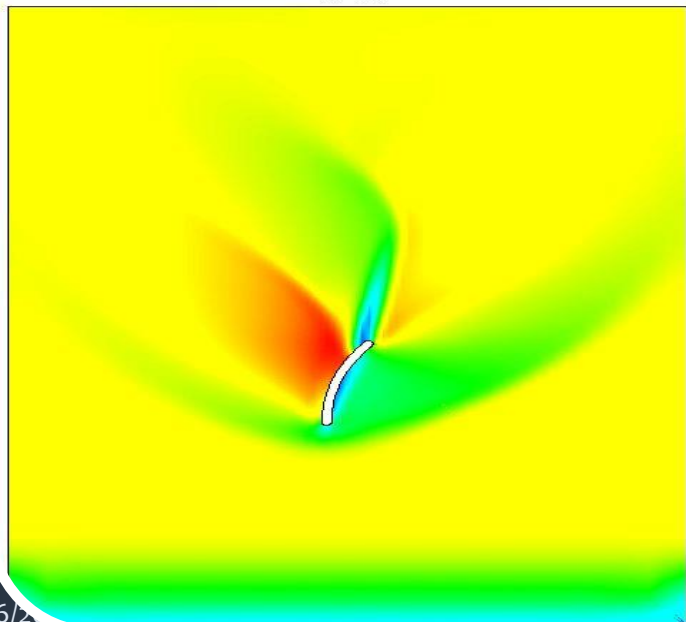

Temperature [K]

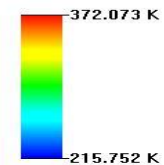
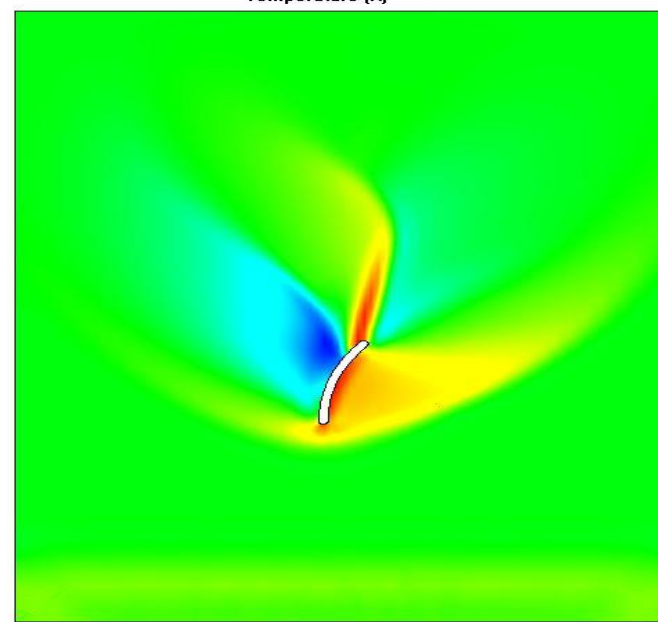

Video Link

- [Flow Simulation](#)
- [Motion Study](#)
- [Engine Animation](#)

Heat Transfer

Electronic Box

(- Temperature-)
conds

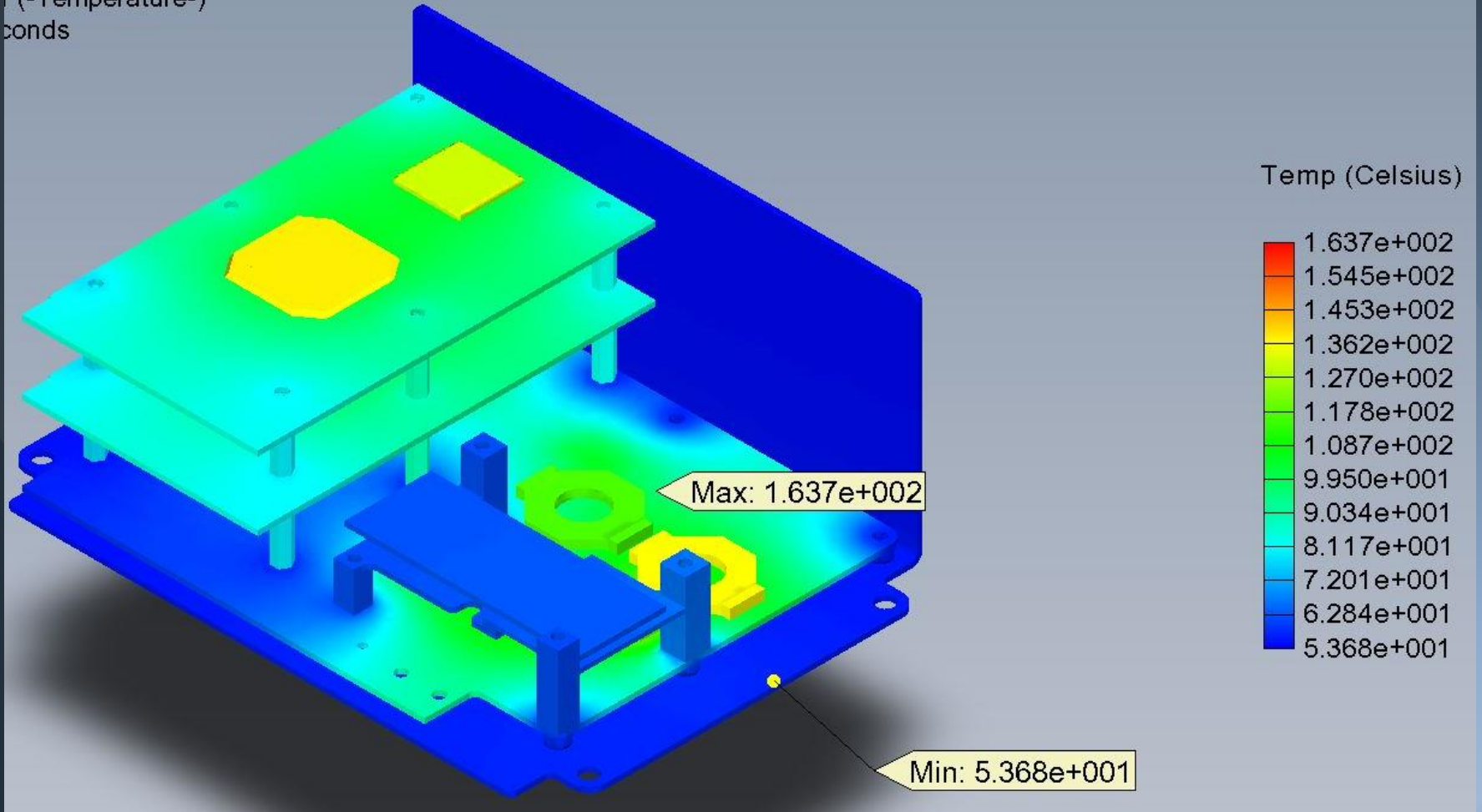

Max: 1.637e+002

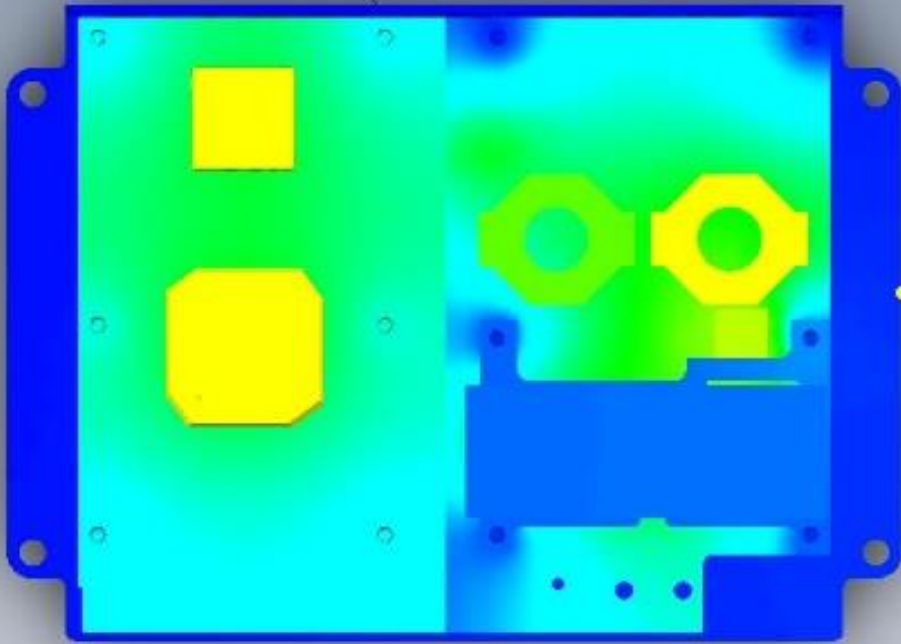

Temp (Celsius)

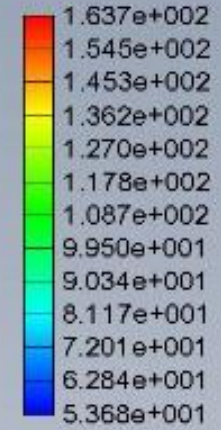

Min: 5.368e+001

Top

time = 400 Seconds

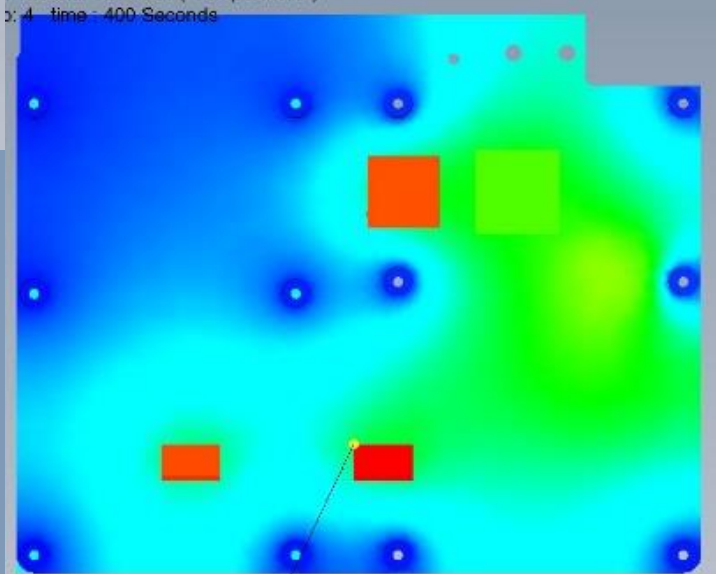

Max: 1.637e+002

Bottom

Electronic Box – Side View

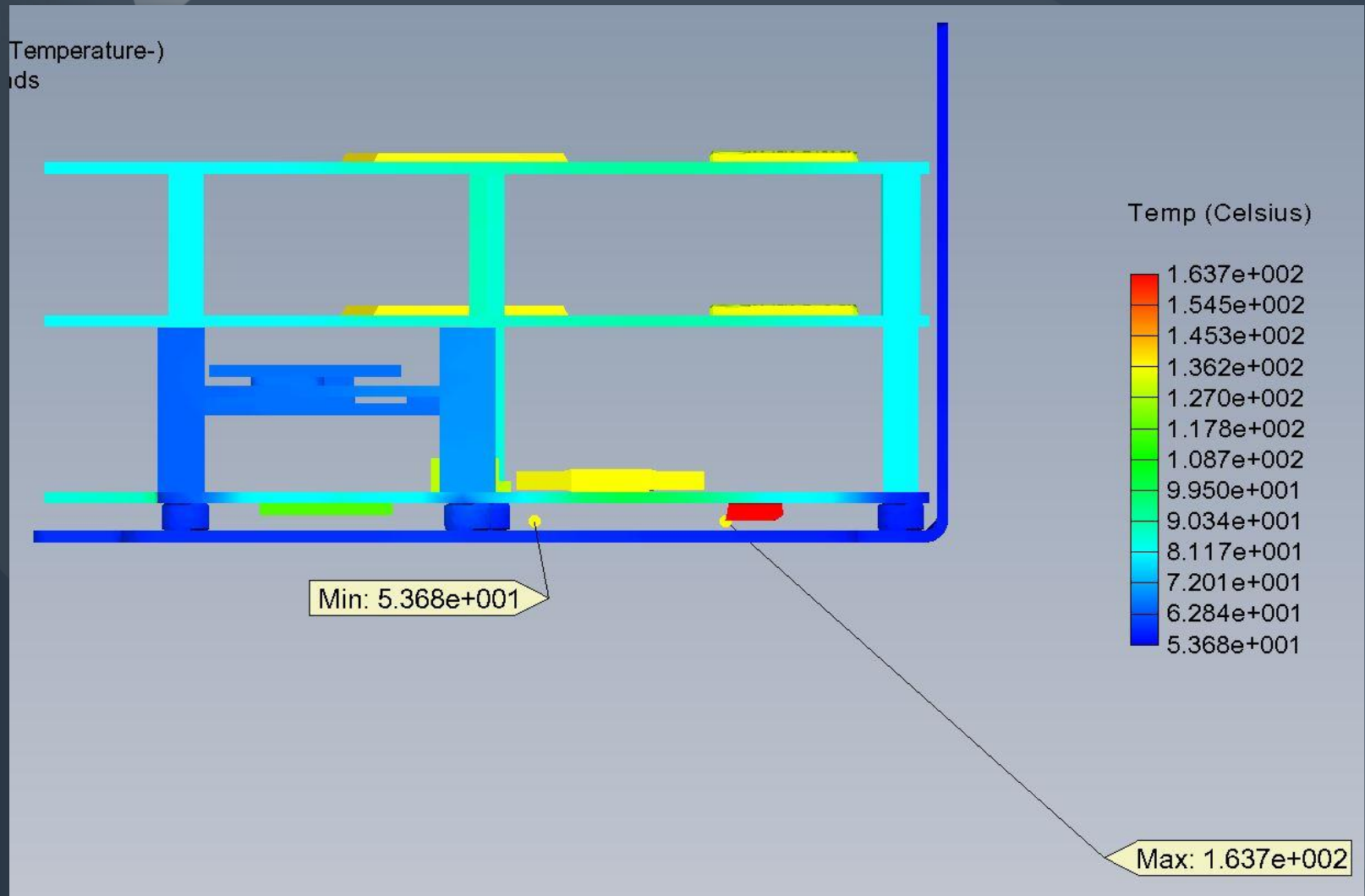

Electronic Box - Front

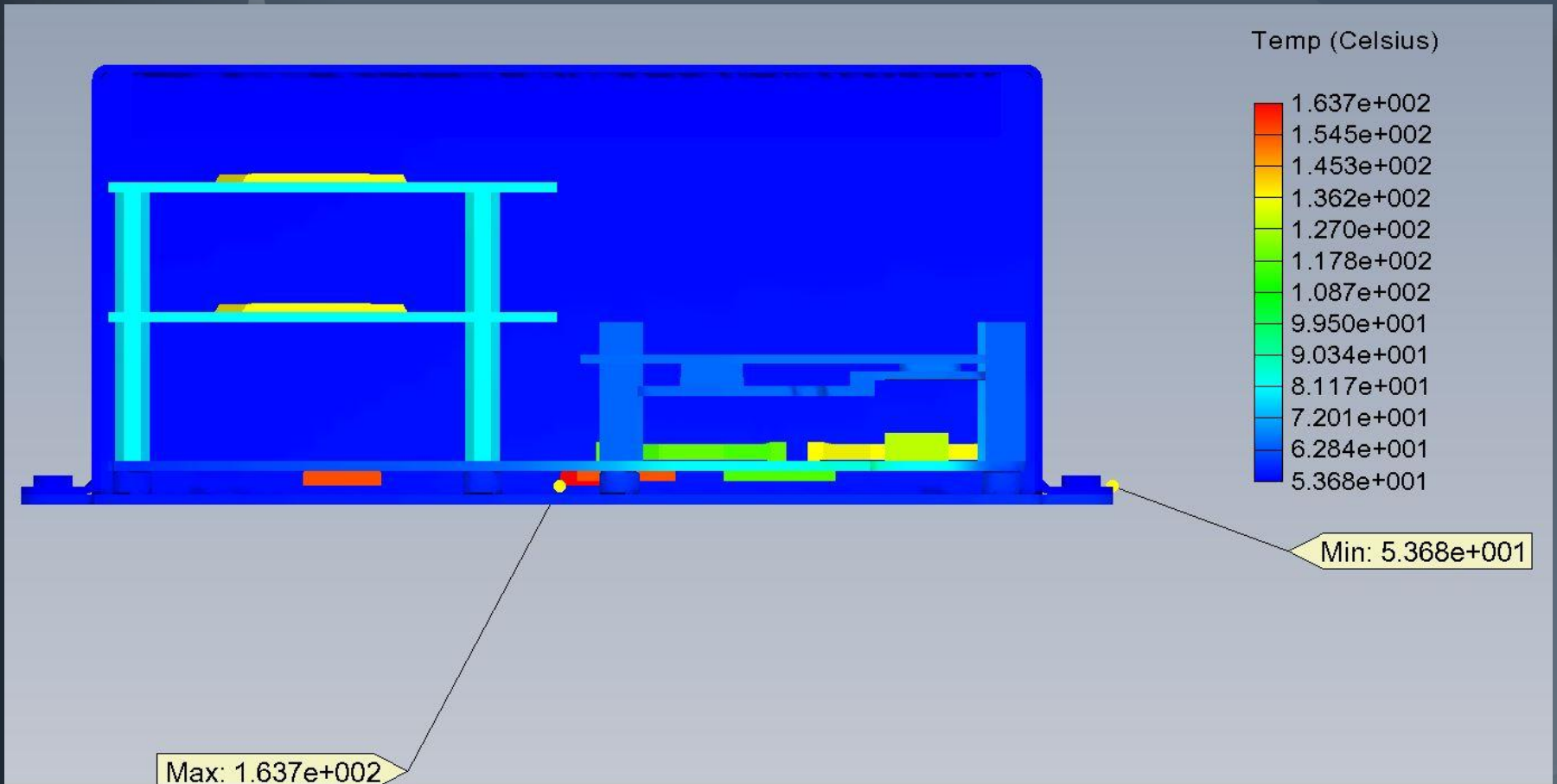

Thank you !

